



nt
magnetics

nuvotem

- Toroidal Filters •
- Storage Chokes •
- Power Inductors •
- Surface Mount Inductors •
- Differential Mode Toroids •
- Common Mode Toroidal Chokes •
- Current Sense Inductors and Transformers •
- Inductors & Transformers for SMPS Applications •

SECTION 4

Inductors and Transformers

For Your Power Magnetic Requirements





Toroidal Chokes, Inductors and Transformers

TALEMA PROFILE

Founded in 1975, The TALEMA International Group has established itself as a world leader in the manufacture of toroidal transformers and related magnetic components. Our strong technical engineering expertise has contributed to the growth of our current workforce to over 1,200 employees in manufacturing locations in the Czech Republic and India.

Over the years The Talema Group has succeeded in designing, producing and delivering millions of transformers to its customers. The recent incorporation of xDSL technology into our extensive range of Telecom and LAN magnetics offerings, such as ISDN, 10Base-T, Ethernet transformers for 100/1000Base-T, has broadened our market offering to an even higher level.

QUALITY

The TALEMA Group has a total commitment to quality and employs Lean Six Sigma training for engineering, production and administrative staff to help achieve a goal of zero defects. All facilities maintain very stringent Quality Control and Quality Assurance procedures and are certified to and manufacture in accordance with ISO-9001:2000, TS-16949:2002 and meet a broad range of International Standards including UL, VDE, IEC, and EN.

TALEMA International Group manufacturing facilities are RoHS compliant and all chokes, inductors and HF components are produced in an EMS facility which is certified to ISO-14001:2004.



CONTENTS

	Pages
CA, CD, CQ & CK Series - Common Mode Toroidal Chokes with sector winding for filtering supply lines having in-phase signals of equal amplitude. THT and SMD Mounting. 0.1 - 17 A, 0.10 to 100 mH.	3 - 8
TVH Series - Common Mode Toroidal EMI Inductors - SMD and THT Mounting. 0.5 - 3.6 A, 1.0 to 22 mH	9
CMP Series - Common Mode Toroidal Chokes - THT and SMD Mounting - 1.22 - 14.0 A, 0.473 - 1.17mH	10 - 11
LCP Series - Miniature SMD High Current Toroidal Inductors designed for use in applications where energy storage is required. Excellent for filtering high frequency signals while supporting a substantial DC current as well as for AC ripple, SMPS and for use with DC-DC Converters. 0.15 to 7.4 Amps, 2.2 to 8800 µH.	12 - 13
LC-1 - Smaller SMD version of the LCP - 0.15 - 3.0 A, 2.2 to 880 µH	14
DJ & DJA Series - High Capacity Linear Storage Chokes for use in SMPS where low losses are essential at high frequencies (to 500kHz). The DJA Series utilizes Fe-based amorphous alloy cores providing high flux density and low core loss. 1.5 to 29 Amps, 500 to 5000µ Joules.	15 - 16
DP Series - Low Cost Power Inductors for EMI filtering and energy storage with operating frequencies to 200 kHz. 0.5 to 15 Amps, 6.8 to 4700 µH.	17 - 20
SA Series - High Efficiency, High Stability Storage Chokes featuring FE-based amorphous alloy cores which allow high flux density and low core loss. Exceptional efficiency and field modulation when used as loading coils for energy storage. Highly stable inductance over a wide DC bias current range and high "Q" with operating frequencies to 500kHz. 0,63 to 20 Amps, 10 to 8200 µH.	21 - 23
SD Series - High Efficiency Storage Chokes designed with MPP cores provide excellent efficiency and field modulation when used as loading coils for energy storage. Highly stable inductance with changing DC bias current. Standard range from 0,63 to 8.0 Amps, 47 to 6000 µH. Custom Range to 63 Amps.	24 - 26
SL Series - SMD & THT Toroidal High Energy Storage Inductors for operating frequencies to 1MHz. Available with single windings and as coupled transformers. 0.72 - 22.4A, 0.6 to 1295µH	27 - 29
SH50 Series - SMD & THT Toroidal Inductors compatible with National Semiconductor's 50kHz Simple Switcher™, part numbers LM2574, LM2475 and LM2576. 0.42 - 3.0A, 47 to 2200µH	30 - 31
SH150 Series - SMD & THT Toroidal Inductors designed for use with National Semiconductor's 150kHz Simple Switcher™, part numbers LM259X-L1 through LN259X-L44 and LM258X-L.	32 - 33
SH260 Series - SMD & THT Toroidal Inductors for National Semiconductor's 260kHz Simple Switcher™, part numbers LM267X-L41 through LM267-L50.	34 - 35
SC Series - Low Profile SMD & THT High Stability Power Inductors. High energy storage with minimum saturation. Operating frequency to 1MHz 1.5 - 14.4A, 2.2 to 202µH	36
Tape and Reel Packaging and Dimensions	37 - 38
Linear Transformers and Inductors for SMPS Applications and Produced to Customer Specifications - Transformers - Drive, Control, Flyback, Current, High Current, Output - Common Mode Chokes & Custom Assemblies employing a wide variation of high frequency winding techniques and construction including: Multi-strand copper, Foil, Litz, Heavy Duty Copper, Triple Insulated Wire and Margin Tapes to name a few.	39 - 41
Authorized Talema Sales Offices and Representatives	43



CA Series • Common Mode Toroidal Chokes

CA Series common mode toroidal chokes provide an efficient means of filtering supply lines having in-phase signals of equal amplitude thus allowing equipment to meet stringent electrical radiation specifications. Wide frequency ranges can be filtered by using high and low inductance Common Mode toroids in series. Differential mode signals can be attenuated substantially when used together with input and output capacitors.

Features

- Separated windings for minimum capacitance
- Meets requirements of EN138100, VDE 0565, part2: 1997-03 and UL1283
- Competitive pricing due to high volume production
- Manufactured in ISO-9001:2000, TS-16949:2002 and ISO-14001:2004 certified Talema facility
- Fully RoHS compliant



Electrical Specifications @ 25°C

Test frequency: Inductance measured at 0.10VAC @ 10kHz

Test voltage between windings: 1,500 VAC for 60 seconds

Operating temperature: -40°C to +125°C

Climatic category: IEC68-1 40/125/56

Part Number	I _{dc} Amp	L _O (mH) ±30% (2x)	DCR mOhm (2x)	Coil Size O.D. x Ht. (Nominal)	Mtg. Style Size		
					B	V / X	F
CA_-0.4-100	0.4	100	2,807	18 x 7	3	3	3
CA_-0.5-100	0.5	100	2,044	23 x 11	5	4	4
CA_-0.6-100	0.6	100	1,543	29 x 13	5	4A	6
CA_-1.4-100	1.4	100	484	35 x 16	8	9	9
CA_-0.4-82	0.4	82	1,167	15 x 8	3	3	3
CA_-0.5-82	0.5	82	1,851	23 x 11	5	4	4
CA_-0.6-82	0.6	82	1,397	29 x 13	5	4A	6
CA_-1.6-82	1.6	82	350	35 x 16	8	9	9
CA_-0.3-68	0.3	68	3,692	15 x 8	3	2	2
CA_-0.5-68	0.5	68	1,853	18 x 7	3	3	3
CA_-0.6-68	0.6	68	1,353	23 x 11	5	4	4
CA_-0.7-68	0.7	68	1,108	29 x 13	5	4A	6
CA_-1.8-68	1.8	68	277	35 x 16	8	9	9
CA_-0.3-56	0.3	56	3,126	14 x 8	3	2	2
CA_-0.5-56	0.5	56	1,518	18 x 7	3	3	3
CA_-0.6-56	0.6	56	1,378	23 x 11	5	4	4
CA_-0.8-56	0.8	56	807	29 x 13	5	4A	6
CA_-2.0-56	2.0	56	228	35 x 16	8	9	9
CA_-0.4-47	0.4	47	1,942	14 x 8	3	2	2
CA_-0.5-47	0.5	47	1,390	18 x 7	3	3	3
CA_-0.6-47	0.6	47	1,001	23 x 11	5	4	4
CA_-0.9-47	0.9	47	658	29 x 13	5	4A	6
CA_-2.2-47	2.2	47	185	35 x 16	8	9	9
CA_-0.4-39	0.4	39	1,769	14 x 8	3	2	2
CA_-0.5-39	0.5	39	1,267	18 x 7	3	3	3
CA_-0.6-39	0.6	39	912	23 x 11	5	4	4
CA_-1.0-39	1.0	39	537	29 x 13	5	4A	6
CA_-2.5-39	2.5	39	150	36 x 17	8	9	9
CA_-0.4-33	0.4	33	1,628	14 x 8	3	2	2
CA_-0.6-33	0.6	33	837	18 x 7	3	3	3
CA_-0.7-33	0.7	33	751	23 x 11	5	4	4
CA_-1.1-33	1.1	33	434	29 x 13	5	5	6
CA_-2.7-33	2.7	33	124	36 x 17	8	9	9
CA_-0.5-27	0.5	27	1,179	14 x 8	3	2	2
CA_-0.8-27	0.8	27	674	18 x 7	3	3	3
CA_-1.0-27	1.0	27	537	23 x 11	5	4	4
CA_-1.4-27	1.4	27	279	30 x 14	5	4A	6
CA_-3.2-27	3.2	27	87	37 x 17	8	9	9
CA_-0.5-22	0.5	22	960	14 x 8	3	2	2
CA_-0.9-22	0.9	22	542	18 x 7	3	3	3
CA_-1.0-22	1.0	22	485	23 x 11	5	4	4
CA_-1.5-22	1.5	22	227	30 x 14	5	4A	6
CA_-3.6-22	3.6	22	70	37 x 17	8	9	9
CA_-0.6-18	0.6	18	868	14 x 8	3	2	2
CA_-1.0-18	1.0	18	439	18 x 7	3	3	3
CA_-1.1-18	1.1	18	388	23x 11	5	4	4
CA_-1.6-18	1.6	18	205	30 x 14	5	4A	6
CA_-3.9-18	3.9	18	57	36 x 17	8	9	9
CA_-0.6-15	0.6	15	793	14 x 8	3	2	2
CA_-1.0-15	1.0	15	401	18 x 7	3	3	3
CA_-1.2-15	1.2	15	315	23 x 11	5	4	4
CA_-1.8-15	1.8	15	167	30 x 14	5	4A	6
CA_-4.3-15	4.3	15	47	36 x 17	8	9	9
CA_-0.7-12	0.7	12	709	14 x 8	3	2	2
CA_-1.1-12	1.1	12	358	18 x 7	3	3	3
CA_-1.4-12	1.4	12	253	23 x 11	5	4	4
CA_-1.9-12	1.9	12	149	30 x 13	5	4A	6
CA_-4.9-12	4.9	12	37	36 x 17	8	9	9
CA_-0.7-10	0.7	10	647	14 x 8	3	2	2
CA_-1.2-10	1.2	10	285	18 x 7	3	3	3
CA_-1.6-10	1.6	10	203	23 x 11	5	4	4
CA_-2.0-10	2.0	10	136	29 x 13	5	4A	6
CA_-5.0-10	5.0	10	34	36 x 17	8	9	9
CA_-1.1-6.8	1.1	6.8	342	14 x 8	3	2	2
CA_-1.3-6.8	1.3	6.8	235	18 x 7	3	3	3
CA_-2.0-6.8	2.0	6.8	148	23 x 11	5	4	4
CA_-2.6-6.8	2.6	6.8	79	30 x 13	5	4A	6
CA_-5.5-6.8	5.5	6.9	28	35 x 16	8	9	9



CA Series • Common Mode Toroidal Chokes

Part Number	I _{DC} Amp	L ₀ (mH) ±30% (2x)	DCR mOhm (2x)	Coil Size O.D. x Ht. (Nominal)	Mtg. Style Size			Part Number	I _{DC} Amp	L ₀ (mH) ±30% (2x)	DCR mOhm (2x)	Coil Size O.D. x Ht. (Nominal)	Mtg. Style Size		
					B	V / X	F						B	V / X	F
CA_-1.2-5.6	1.2	5.6	276	14 x 8	3	2	2	CA_-1.9-1.2	1.9	1.2	71	14 X 8	3	2	2
CA_-1.5-5.6	1.5	5.6	193	18 x 7	3	3	3	CA_-3.1-1.2	3.1	1.2	44	18 X 7	3	3	3
CA_-2.0-5.6	2.0	5.6	120	23 x 11	5	4	4	CA_-5.0-1.2	5.0	1.2	20	23 X 11	5	4	4
CA_-2.8-5.6	2.8	5.6	72	29 x 13	5	4A	6	CA_-7.5-1.2	7.5	1.2	10	30 X 41	5	5	6
CA_-5.9-5.6	5.9	5.6	26	35 x 16	8	9	9	CA_-9.6-1.2	9.6	1.2	10	33 x 14	8	9	9
CA_-1.2-4.7	1.2	4.7	253	14 x 8	3	2	2	CA_-2.0-1.0	2.0	1.0	65	14 X 8	3	2	2
CA_-1.6-4.7	1.6	4.7	110	18 x 7	3	3	3	CA_-3.5-1.0	3.5	1.0	32	18 X 6	3	3	3
CA_-1.9-4.7	1.9	4.7	99	23 x 11	5	4	4	CA_-5.0-1.0	5.0	1.0	18	23 X 11	5	4	4
CA_-3.0-4.7	3.0	4.7	58	29 x 13	5	5	6	CA_-7.8-1.0	7.8	1.0	9	30 X 14	5	5	6
CA_-6.2-4.7	6.2	4.7	23	34 x 15	8	9	9	CA_-10-1.0	10	1.0	9	33 x 14	8	9	9
CA_-1.3-3.9	1.3	3.9	230	14 x 8	3	2	2	CA_-2.8-0.68	2.8	0.68	37	14 X 8	3	2	2
CA_-1.8-3.9	1.8	3.9	100	18 x 7	3	3	3	CA_-4.2-0.68	4.2	0.68	21	18 X 7	3	3	3
CA_-2.1-3.9	2.1	3.9	81	23 x 11	5	4	4	CA_-6.0-0.68	6.0	0.68	13	23 X 11	5	4	4
CA_-3.5-3.9	3.5	3.9	42	30 x 14	5	5	6	CA_-8.5-0.68	8.5	0.68	7	30 X 14	5	4A	6
CA_-6.8-3.9	6.8	3.9	19	34 x 15	8	9	9	CA_-11-0.68	11	0.68	7	33 x 14	8	9	9
CA_-1.5-3.3	1.5	3.3	165	14 x 8	3	2	2	CA_-3.6-0.47	3.6	0.47	28	14 X 8	3	2	2
CA_-2.0-3.3	2.0	3.3	92	18 x 7	3	3	3	CA_-6.0-0.47	6.0	0.47	11	18 X 7	3	3	3
CA_-3.0-3.3	3.0	3.3	52	23 x 11	5	4	4	CA_-7.0-0.47	7.0	0.47	10	23 X 11	5	4	4
CA_-4.0-3.3	4.0	3.3	34	30 x 14	5	5	6	CA_-9.5-0.47	9.5	0.47	6	29 X 13	5	5	6
CA_-7.5-3.3	7.5	3.3	16	34 x 15	8	9	9	CA_-12-0.47	12	0.47	6	32 x 13	8	9	9
CA_-1.5-2.7	1.5	2.7	172	14 x 8	3	2	2	CA_-3.2-0.33	3.2	0.33	17	14 X 8	3	2	2
CA_-2.2-2.7	2.2	2.7	83	18 x 7	3	3	3	CA_-6.1-0.33	6.1	0.33	7	18 X 6	3	3	3
CA_-3.5-2.7	3.5	2.7	47	23 x 11	5	4	4	CA_-7.2-0.33	7.2	0.33	7	23 X 11	5	4	4
CA_-4.8-2.7	4.8	2.7	22	30 x 14	5	5	6	CA_-10-0.33	10	0.33	5	29 X 13	5	4A	6
CA_-7.8-2.7	7.8	2.7	14	34 x 15	8	9	9	CA_-13-0.33	13	0.33	5	32 x 13	8	9	9
CA_-1.6-2.2	1.6	2.2	135	14 x 7	3	2	2	CA_-3.7-0.22	3.7	0.22	12	14 X 8	3	2	2
CA_-2.3-2.2	2.3	2.2	75	18 x 7	3	3	3	CA_-7.6-0.22	7.6	0.22	5	18 X 7	3	3	3
CA_-4.0-2.2	4.0	2.2	30	23 x 11	5	4	4	CA_-8.9-0.22	8.9	0.22	4	23 X 11	5	4	4
CA_-5.8-2.2	5.8	2.2	16	31 x 15	5	5	6	CA_-11-0.22	11	0.22	4	29 X 12	5	5	6
CA_-8.2-2.2	8.2	2.2	13	34 x 15	8	9	9	CA_-13-0.22	13	0.22	4	32 x 13	8	9	9
CA_-1.6-1.8	1.6	1.8	111	14 x 8	3	2	2	CA_-4.6-0.15	4.6	0.15	8	14 X 8	3	2	2
CA_-2.5-1.8	2.5	1.8	60	18 x 7	3	3	3	CA_-9.3-0.15	9.3	0.15	3	18 X 7	3	3	3
CA_-4.5-1.8	4.5	1.8	27	23 x 11	5	4	4	CA_-10-0.15	10	0.15	3	23 X 11	5	4	4
CA_-6.0-1.8	6.0	1.8	14	30 x 14	5	5	6	CA_-12-0.15	12	0.15	3	29 X 12	5	5	6
CA_-8.7-1.8	8.7	1.8	12	34 x 15	8	9	9	CA_-16-0.15	16	0.15	3	32 x 13	8	9	9
CA_-1.8-1.5	1.8	1.5	89	14 X 8	3	2	2	CA_-5.7-0.10	5.7	0.10	5	14 X 8	3	2	2
CA_-2.8-1.5	2.8	1.5	49	18 X 7	3	3	3	CA_-10-0.10	10	0.10	2	18 X 7	3	3	3
CA_-5.0-1.5	5.0	1.5	22	23 X 11	5	4	4	CA_-12-0.10	12	0.10	2	22 X 11	5	4	4
CA_-7.0-1.5	7.0	1.5	11	31 X 15	5	5	6	CA_-13-0.10	13	0.10	3	28 X 12	5	5	6
CA_-9.1-1.5	9.1	1.5	11	33 x 14	8	9	9	CA_-17-0.10	17	0.10	3	32 X 13	8	9	9

Talema's Engineering staff can assist in the design of other inductance values and sizes.

Notes:

- Inductance measured at 25°C and 10 kHz.
L < 2mH test level < 2.5mA
L > 2mH test level < 250mV
- Inductance loss <10% by DC preload with I_N (current compensated).
- DC Resistance measured at 25°C ±5°C.
- Test voltage per VDE 0565/2
- 250 VAC Nominal Operating Voltage
- Maximum Ambient Temperature: 60°C

Ordering Key

CA B - 0.5 - 10mH

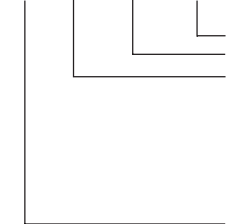

Inductance Value per Winding
Current Rating (Amps)
Mounting Style
O = Open: 'OV' - Vertical & 'OH' - Horizontal Mount
B = Base Mount
V = Vertical Encapsulated - Pins 7 - 2 and 6 - 3
X = Vertical Encapsulated - Pins 8 - 1 and 5 - 4
F = Flat Encapsulated
Basic Series Designation

Mounting Style • CA Series • Common Mode Toroidal Chokes

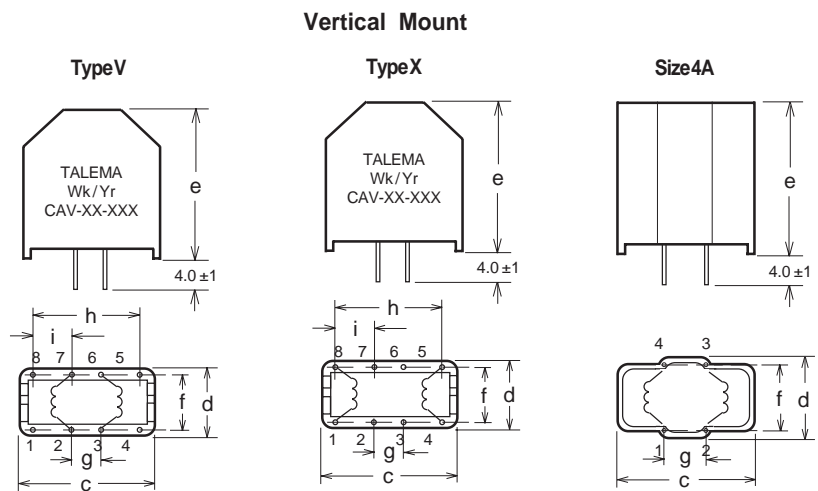
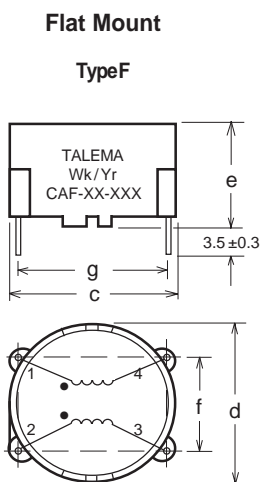
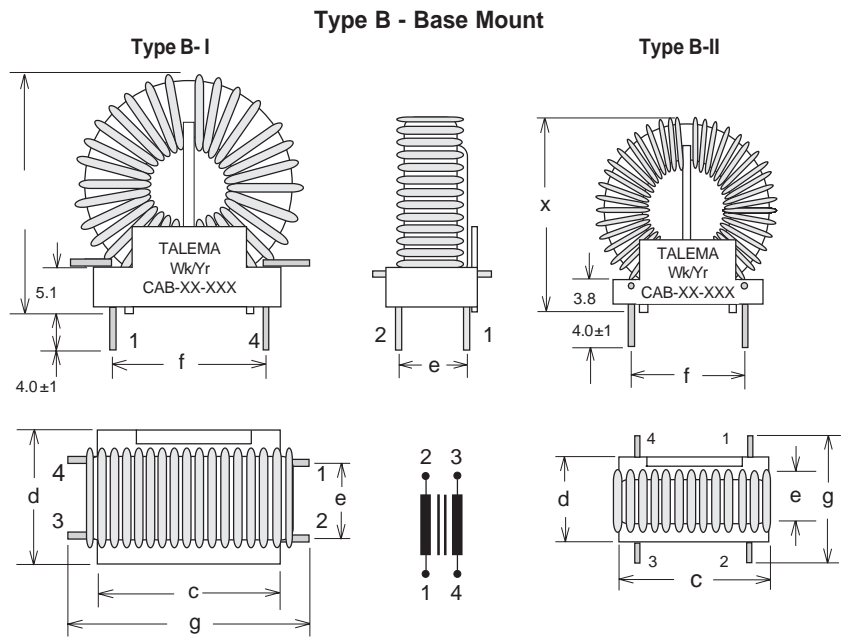
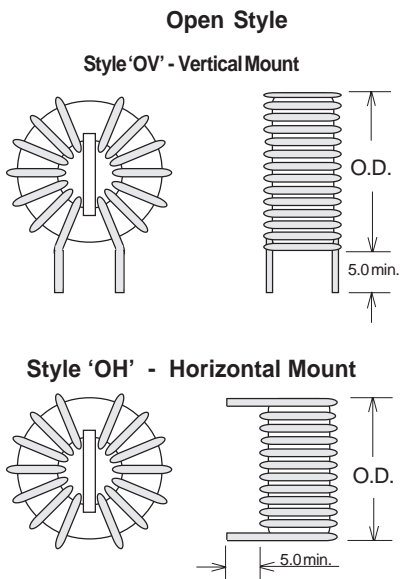

Mounting Style	Size Code	Dimensions									
		Nominal (mm)									
		c	d	e	f	g	h	i	x	Pin Ø	
Base Mount	B- II	3	19.1	10.8	6.4	15.2	15.9	--	--	Coil O.D. + 3.8	1.02
	B- I	5	25.4	16.0	10.2	20.3	34.3	--	--	Coil O.D. + 3.5	1.27
		8	27.9	20.3	15.2	22.9	36.8	--	--		
Vertical Mount	"V"	2	17.8	12.8	20.0	10.0	5.0	15.0	5.0	--	0.60 x 0.88
	Pins	3	23.0	15.5	25.0	12.5	10.0	20.0	5.0	--	
	7-2 & 6-3	4	27.0	18.0	30.0	15.0	12.5	22.5	5.0	--	0.60 x 0.88
	"X"	4A	32.5	18.0	35.0	15.0	12.5	--	--	--	
	Pins	5	32.0	20.5	35.0	17.5	12.5	27.5	7.5	--	
	8-1 & 5-4	9	43.0	28.0	47.5	25.0	25.0	40.0	7.5	--	0.75 x 1.10
Flat Mount	F	2	17.5	17.0	12.5	10.0	15.0	--	--	--	0.60 x 0.88
		3	22.5	22.0	15.0	12.5	20.0	--	--	--	
		4	27.5	27.0	17.5	15.0	25.0	--	--	--	0.60 x 0.88
		6	32.5	32.0	20.0	20.0	30.0	--	--	--	
		9	42.5	42.0	28.5	25.0	35.0	--	--	--	



CD & CQ Series CM Interface Chokes for Data and Signal Lines

Features

- High attenuation over a wide frequency range
- Low interwinding and coupling capacitance
- Wide inductance range
- Excellent quality at extremely competitive price due to high volume production
- Manufactured in an ISO-9001:2000, TS-16949:2002 and ISO-14001:2004 certified Talema facility
- Other inductance values available upon request
- Fully RoHS compliant and meets lead free reflow level J-STD-020C



Electrical Specifications @ 25°C

Nominal Voltage: 42Vac (50/60Hz), 80Vdc

Operating Temperature: -25° to +85°C

Storage Temperature: -40° to +125°C

Climatic category: according to IEC68-1 25/85/56

Test voltage between windings: 500 Vrms

Test frequency

Nominal Inductance: measured @ 100kHz/20 mVrms

Leakage Inductance: measured @ 100kHz, 100mVrms

Test Equipment: HP4192A

Part Number	L_N (μH) $\pm 30\%$	I_N (mA)	L_L (μH)	R_{Cu} (mOhms)	V_P (Vrms)	Windings per Core	Package	Schematic
CD Series - Double Chokes for EMI noise suppression								
CD_-1.0-A	1000	600	0.25	190	500	2	F / V / J	A
CD_-1.7-A	1700	550	0.42	200	500	2	F / V / J	A
CD_-2.2-A	2200	350	0.45	300	500	2	F / V / J	A
CD_-3.3-A	3300	350	0.50	370	500	2	F / V / J	A
CD_-4.7-A	4700	350	0.40	600	500	2	F / V / J	A
CD_-6.8-A	6800	350	0.55	510	500	2	F / V / J	A
CD_-10-A	10000	350	0.65	620	500	2	F / V / J	A
CD_-12-A	12000	300	0.70	680	500	2	F / V / J	A
CD_-15-A	15000	300	0.55	720	500	2	F / V / J	A
CD_-22-A	22000	300	0.85	920	500	2	F / V / J	A
CD_-28-A	28000	300	0.95	1020	500	2	F / V / J	A
CD_-33-A	33000	300	1.90	1120	500	2	F / V / J	A
CD_-50-A	50000	300	1.35	1800	500	2	F / V / J	A
CD_-70-A	70000	300	2.50	2100	500	2	F / V / J	A
CQ Series - Quad Chokes for EMI noise suppression								
CQ_-1.0-B	1000	400	0.30	200	500	4	F / V / J	B
CQ_-1.7-B	1700	350	0.40	260	500	4	F / V / J	B
CQ_-2.2-B	2200	300	0.45	310	500	4	F / V / J	B
CQ_-3.3-B	3300	300	0.50	380	500	4	F / V / J	B
CQ_-5.0-B	5000	300	0.30	430	500	4	F / V / J	B
CQ_-6.8-B	6800	300	0.55	850	500	4	F / V / J	B
CQ_-10-B	10000	300	0.65	1060	500	4	F / V / J	B
CQ_-12-B	12000	250	0.65	1120	500	4	F / V / J	B
CQ_-58-B	58000	200	1.40	2400	500	4	F / V / J	B
CQ_-90-B	90000	150	2.00	4150	500	4	F / V / J	B

When ordering Series CD or CQ, use suffix "F", "V" or "J" to designate desired package style.

CD/CQF = Flat package, through-hole

CDV/CQV = Vertical package, through hole

CDJ/CQJ = Flat package, surface mount

Packaging Style and Impedance Performance

Dimensions: Inches (Millimeters)

Package Style

Tolerance: ± 0.010 (0.25) unless specified otherwise

CDF / CQF

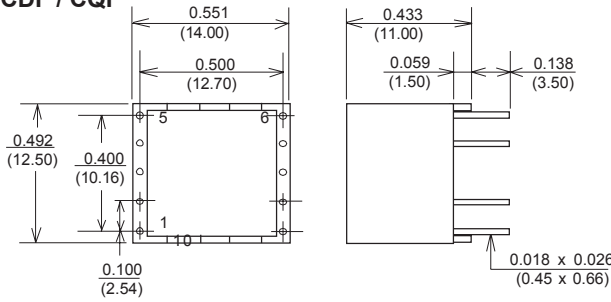

CDV / CQV

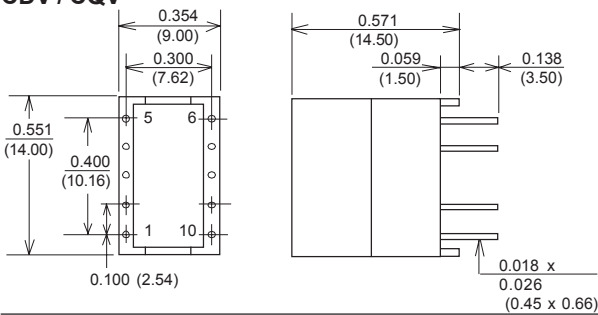

CDJ / CQJ

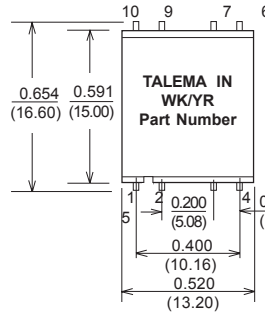

Suggested Pad Layout

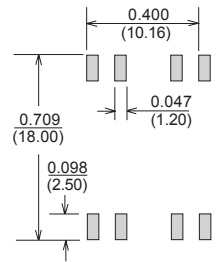

Schematics

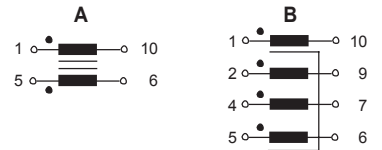

Note: Parts will be supplied with only the pins shown on schematics A (types CDF, CDV & CDJ) and B (types CQF, CQV & CQJ)

Surface Coplanarity will be 0.004(0.10) maximum

Impedance Performance CDx & CDx Series Double Chokes

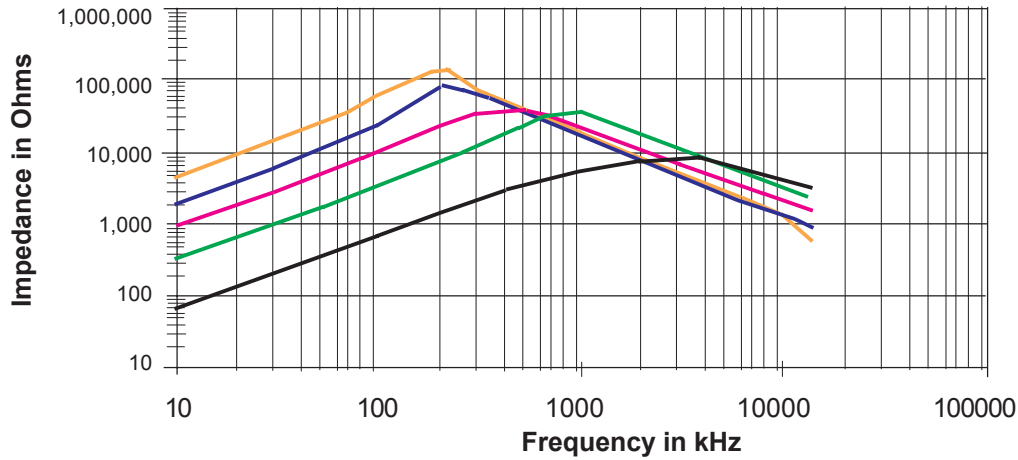

CQx & CDx Series Quad Chokes

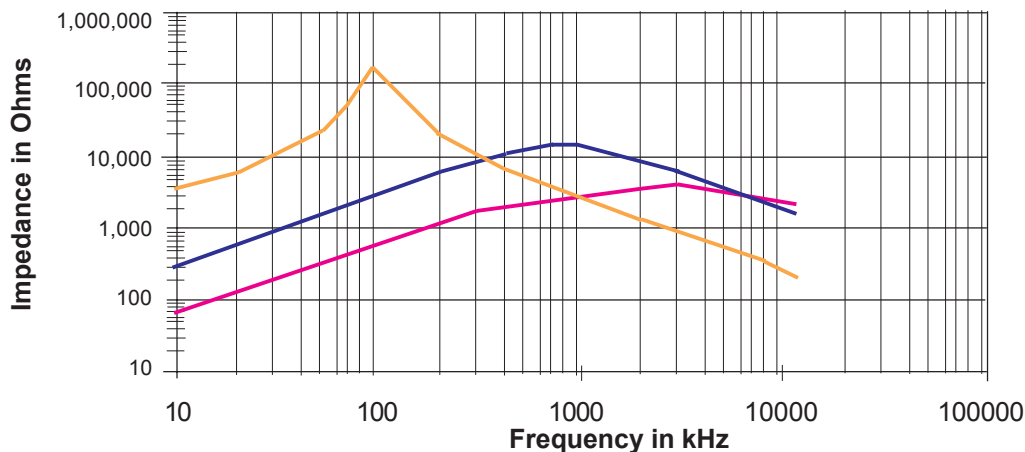



CKV Series • Current Compensated Double Chokes for Power Lines

Features

- High attenuation over a wide frequency range
- Low interwinding and coupling capacitance
- Sector Winding
- Manufactured in an ISO-9001:2000, TS-16949:2002 and ISO-14001:2004 certified Talema facility
- Flame retardant case per UL94V-O
- Other inductance values available upon request
- fully RoHS compliant

Electrical Specifications @ 25°C

Rated Voltage: 250Vac

Rated current @ 50/60Hz and 40°C ambient

Operating Temperature: -40° to +85°C

Storage Temperature: -40° to +125°C

Climatic category: according to IEC68-1 40/85/56

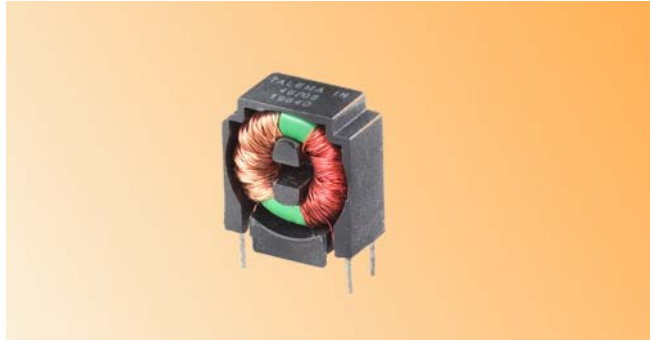

Test voltage: 1500 Vac, 2s line to line

Test Equipment: HP4192A

Weight: ~ 3 grams

CKV Series - Current Compensated Double Chokes for Power Lines

Part Number	L_N (μ H) -30/+50%	I_N (mA)	L_L (μ H)	R_{CU} (mOhms)	V_P (Vrms)	Windings per Core	Schematic
CKV-4.7-S	4700	700	70	440	1500	2	A or B
CKV-6.8-S	6800	600	100	630	1500	2	A or B
CKV-10-S	10000	500	150	1000	1500	2	A or B
CKV-15-S	15000	400	225	1350	1500	2	A or B
CKV-30-S	30000	300	400	2200	1500	2	A or B
CKV-47-S	47000	250	750	2400	1500	2	A or B

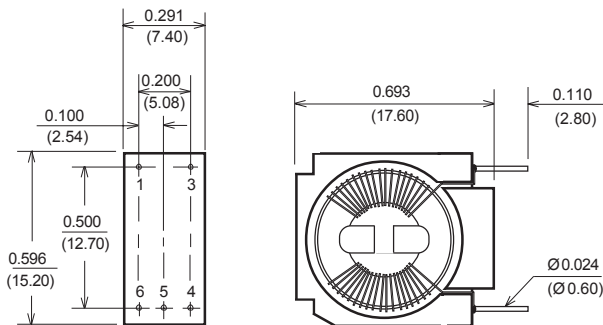

TALEMA IN
Part Nr.
Wk/Yr

Dimensions: Inches (Millimeters)

Tolerance: ± 0.010 (0.25) unless specified otherwise

Schematic

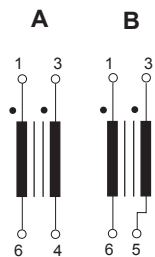

Note: Normal pinning will be 1-3-4-6 Schematic A. If pinning 1-3-5-6 is required, Schematic B should be specified when ordering.

Impedance Performance Sector Winding

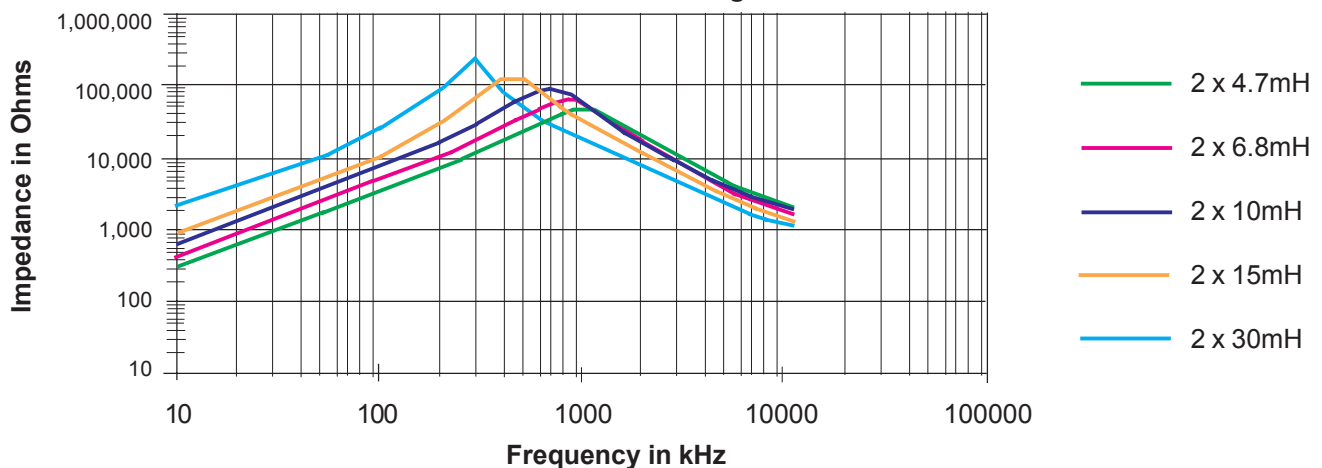



TVH Series • Common Mode EMI Inductors

TVH Series low cost toroidal inductors designed to attenuate conductor noise (EMI) in systems

Features

- SMD design ideal for pick and place compatability
- Manufactured in ISO-9001:2000, TS-16949:2002 and ISO-14001:2004 certified Talema facility
- Meets lead free reflow level J-STD-020C
- Fully RoHS compliant

Electrical Specifications @ 25°C

Test voltage between windings: 500 Vrms
 Operating temperature range: -40°C to +125°C
 Climatic Category: IEC68-1 40/125/56
 Test frequency: Inductance measured @ 10kHz / 10mV



Part Number	Rated RMS Current (Amps)	L _N (mH ±30%)	DCR (mOhm max.)	SRF (MHz)	Vrms	Package Size	
						"S"	"T"
TVH_-3.6-102	3.60	1.0	50	4	1500	SC5	TC5
TVH_-1.5-152	1.50	1.5	60	2	1500	SC3	TC2
TVH_-2.5-302	2.50	3.0	80	2.2	1500	SC5	TC5
TVH_-1.0-103	1.00	10.0	450	0.5	1500	SC3	TC3
TVH_-0.5-223	0.50	22.0	850	0.3	1500	SC3	TC3

Note: When ordering, add "S" or "T" to the basic part number to denote preferred mounting style. Example: TVHS-1.0-223 for SMD or TVHT-1.0-223 for through hole.

Dimensions

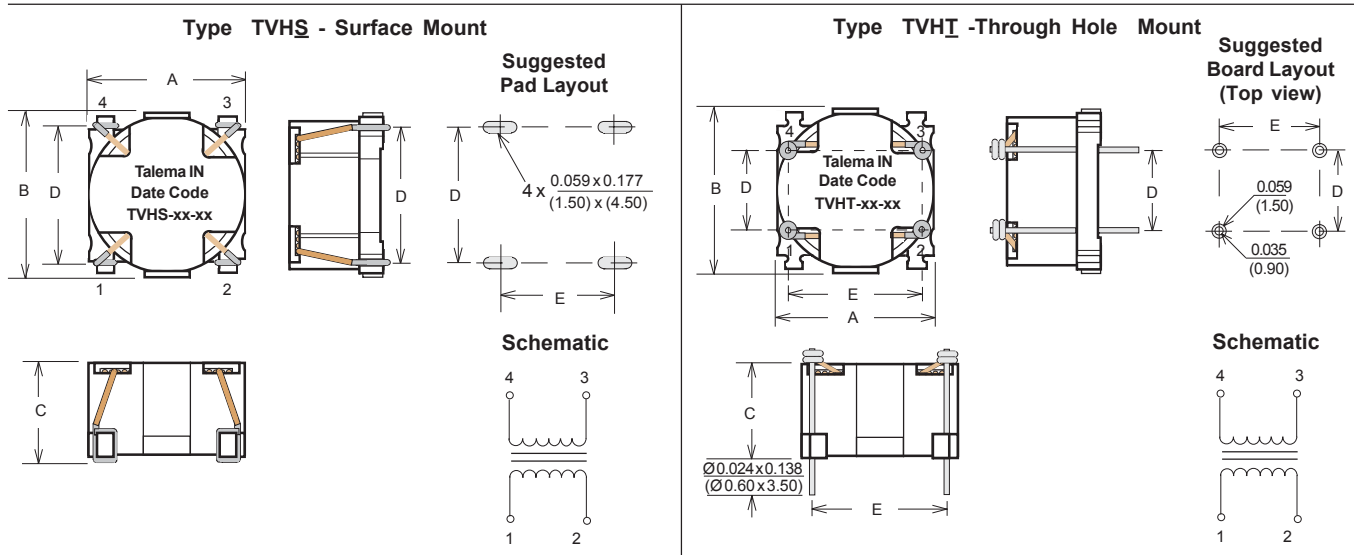

Mounting Style	Size Code	Dimensions - Inches ±0.010 (mm±0.25)				
		A	B	C	D	E
"S" SMD	SC3	0.551 (14.00)	0.630 (16.00)	0.350 max. (8.90 max.)	0.530 (13.46)	0.340 (8.64)
	SC5	0.662 (16.82)	0.760 (19.31)	0.390 max. (9.90 max.)	0.660 (16.76)	0.445 (11.30)
"T" TH	TC3	0.551 (14.00)	0.630 (16.00)	0.327 max. (8.30 max.)	0.500 (12.70)	0.400 (10.16)
	TC5	0.662 (16.82)	0.760 (19.31)	0.362 max. (9.20 max.)	0.500 (12.70)	0.500 (12.70)

THE TALEMA GROUP • Magnetic Components for Universal Applications



CMP Series Common Mode Toroidal Chokes

Features

- Designed for DC/DC Converters
- Excellent Impedance characteristics with optimum size to current ratio
- SMD design ideal for pick and place compatability
- Manufactured in ISO-9001:2000, TS-16949:2002 and ISO-14001:2004 certified Talema facility
- Meets lead free reflow level J-STD-020C
- Fully RoHS compliant

Electrical Specifications @ 25°C

Test voltage between windings: 1000 Vrms

Operating temperature range: -40°C to +125°C

Climatic Category: IEC68-1 40/125/56

Test frequency: Inductance measured @ 10kHz / 10mV



Part Number	Turns Ratio ±2%	Rated Current (I _{DC})	Inductance (mH) ±35%	Leakage Inductance (µH Nominal)	DCR Maximum (mOhm)	Package Size Code		Impedance Curve	Weight (Grams)
						SMD	THT		
CMP_-1.22-1.17	1 : 1	1.22	1.170	8.296	200	SC2	TC2	A	1.1
CMP_-1.63-0.88	1 : 1	1.63	0.884	5.807	110	SC2	TC2	B	1.3
CMP_-2.80-1.47	1 : 1	2.80	1.470	9.630	80	SC5	TC5	C	4.0
CMP_-3.30-1.32	1 : 1	3.30	1.320	8.130	60	SC5	TC5	D	4.3
CMP_-3.30-0.23	1 : 1	3.30	0.225	8.175	60	SC5	TC5	E	4.4
CMP_-4.70-0.77	1 : 1	4.70	0.768	4.559	40	SC5	TC5	F	4.6
CMP_-5.60-0.59	1 : 1	5.60	0.590	3.891	20	SC5	TC5	J	5.0
CMP_-7.20-0.53	1 : 1	7.20	0.530	4.536	15	SHC6	THC6	H	7.3
CMPS-9.70-0.81	1 : 1	9.70	0.809	7.408	14	SHC7	--	F	13.0
CMPS-11.6-0.63	1 : 1	11.6	0.630	5.482	10	SHC7	--	J	14.0
CMPS-14.0-0.47	1 : 1	14.0	0.473	4.531	8	SHC7	--	G	14.0

Note: When ordering, add "S" or "T" to the basic part number to denote preferred mounting style. **Example:** CMPS-1.22-1.17 for SMD or CMPT-1.22-1.17 for through hole.

IMPEDANCE CURVES

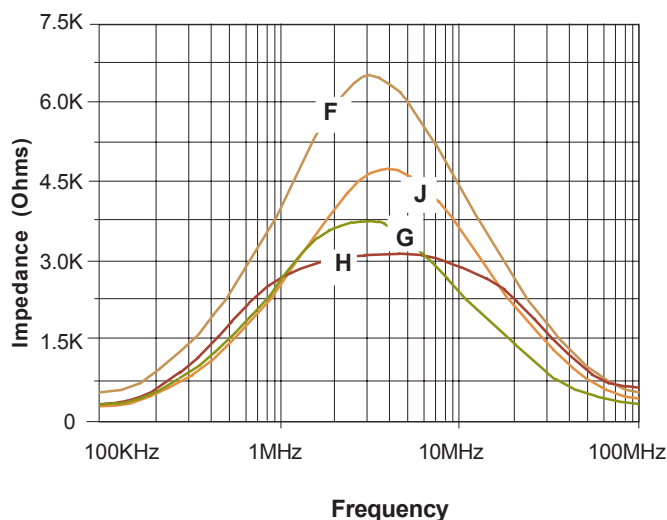
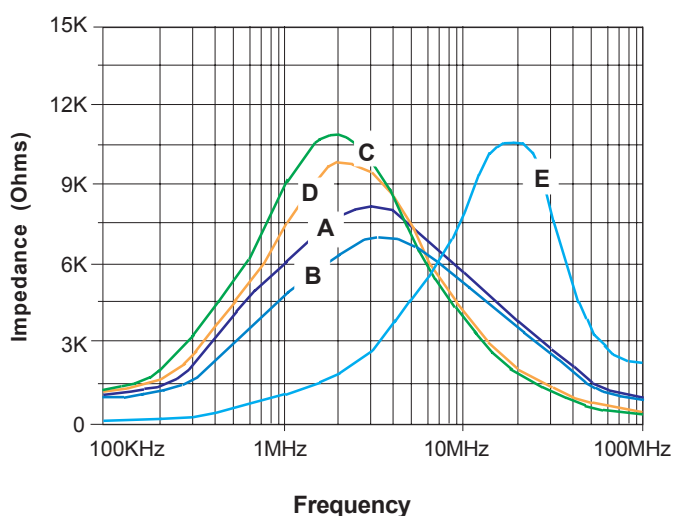

CMP Series Surface Mount Common Mode Toroidal Chokes

SC2 & 5

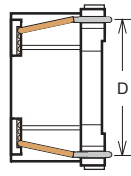
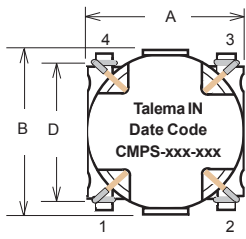

Suggested Pad Layout

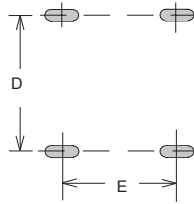

Schematic

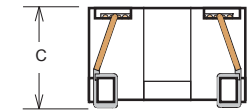
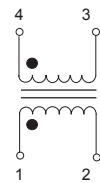

Surface Coplanarity will be <math><0.005(0.13)</math>

TC2, 5 & THC6

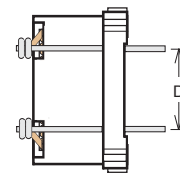
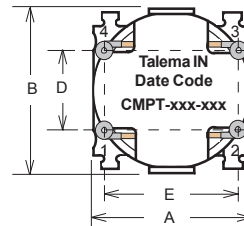

Suggested Board Layout (Topview)

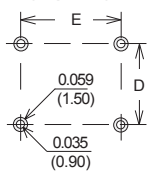

Schematic

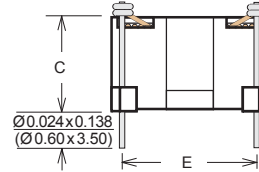
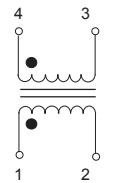

SHC 6

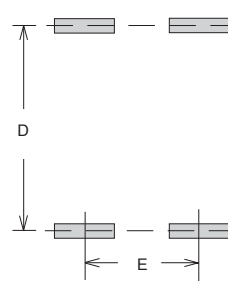
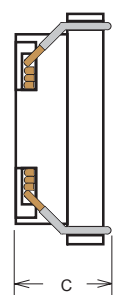
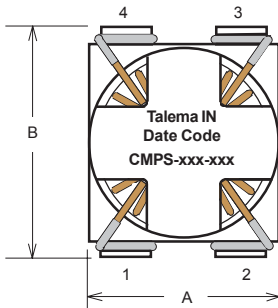

Schematic

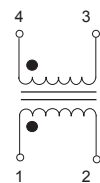

SHC 7

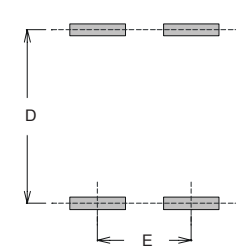
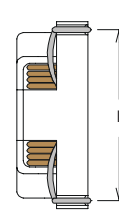
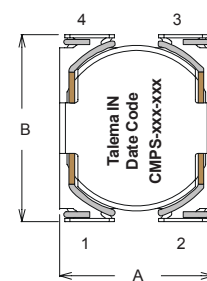

Schematic

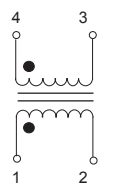

Mounting Style	Size Code	Dimensions - Inches ± 0.010 - mm (± 0.25)						
		A	B	C	D	E	Pad Length	Pad Width
SMD	SC2	0.472 (12.00)	0.472 (12.00)	0.213 (5.40)	0.410 (10.40)	0.330 (8.38)	4 x 0.175(4.45)	4 x 0.060(1.52)
	SC5	0.662 (16.82)	0.760 (19.31)	0.390 (9.91)	0.660 (16.76)	0.445 (11.30)	4 x 0.175(4.45)	4 X 0.060(1.52)
	SHC6	1.000 (25.40)	1.104 (28.05)	0.394 (10.00)	1.010 (25.65)	0.620 (15.75)	4 x 0.300(7.62)	4 x 0.080 (2.03)
	SHC7	1.000 (25.40)	1.220 (30.99)	0.500 (12.70)	1.100 (27.94)	0.600 (15.24)	4 x 0.400(10.16)	4 x 0.155 (3.94)
THT	TC2	0.472 (12.00)	0.472 (12.00)	0.198 (5.02)	0.400 (10.16)	0.350 (8.89)	NA	NA
	TC5	0.662 (16.82)	0.760 (19.31)	0.362 (9.20)	0.500 (12.70)	0.500 (12.70)	NA	NA
	THC6	1.000 (25.40)	1.104 (28.05)	0.358 (9.08)	1.000 (25.40)	0.600 (15.24)	NA	NA



LCP Series • Miniature Low Cost Toroidal Inductors

LCP Series surface mount toroidal inductors are designed for use in applications where energy storage is required for maintenance of a highly stable inductance when a rapid change in load current occurs. These inductors are excellent for filtering high frequency signals while supporting a substantial DC current as well as for AC ripple, switch mode power supplies and for use with DC-DC Converters.

Features

- Operating frequency to 1 MHz
- High energy storage with minimum saturation
- High stability from no load to full load
- Designed as 1:1 Coupled Inductor (Series or Parallel) or as 1:1 Isolation Transformer
- Manufactured in ISO-9001:2000, TS-16949:2002 and ISO-14001:2004 certified Talema facility
- Meets lead free reflow level J-STD-020C
- Fully RoHS compliant

Applications

DC-DC Converters • Common Mode Filter • Computer Note Books
Pulse Modulation Switching Regulators: Step-up, Step-down,
Inverting or dual output • Filtering Battery Powered Equipment



Electrical Specifications @ 25°C

Test voltage between windings: 500 Vrms

Operating temperature range: -40°C to +125°C

Climatic Category: IEC68-1 40/125/56

Test frequency: Inductance measured @ 10kHz/10mV

Part Number	Parallel Connected			Series Connected			Energy Storage (µJ) *	Dimensions Inches(Millimeters)				
	Full Load Current (A _{DC})	L ₀ (µH) ±15% No Load	DCR mOhm	Full Load Current (A _{DC})	L ₀ (µH) ±15% No Load	DCR mOhm		A	B	C	D	H
LCP1-3.00-2.2	3.00	2.2	9	1.50	8.8	36	7.0	0.276 (7.0)	0.276 (7.0)	0.236 (6.0)	0.059 (1.5)	0.201 (5.1)
LCP1-2.10-4.7	2.10	4.7	16	1.05	18.8	64	7.2					
LCP1-1.40-10	1.40	10	37	0.70	40	148	7.2					
LCP1-1.10-15	1.10	15	58	0.55	60	232	7.0					
LCP1-0.92-22	0.92	22	86	0.46	88	344	7.1					
LCP1-0.76-33	0.76	33	133	0.38	132	532	7.2					
LCP1-0.64-47	0.64	47	205	0.32	188	820	7.1					
LCP1-0.54-68	0.54	68	307	0.27	272	1228	7.2					
LCP1-0.44-100	0.44	100	376	0.22	400	1504	7.2					
LCP1-0.36-150	0.36	150	719	0.18	600	2876	7.2					
LCP1-0.30-220	0.30	220	866	0.15	880	3464	7.3					
LCP2-4.40-2.2	4.40	2.2	7	2.20	8.8	28	16.4	0.354 (9.0)	0.354 (9.0)	0.299 (7.6)	0.067 (1.7)	0.248 (6.3)
LCP2-3.10-4.7	3.10	4.7	13	1.55	18.8	52	16.0					
LCP2-2.08-10	2.08	10	28	1.04	40	112	16.4					
LCP2-1.68-15	1.68	15	52	0.84	60	208	16.0					
LCP2-1.40-22	1.40	22	70	0.70	88	280	16.2					
LCP2-1.32-33	1.32	33	83	0.66	132	332	16.0					
LCP2-1.08-47	1.08	47	139	0.54	188	556	21.2					
LCP2-0.80-68	0.80	68	241	0.40	272	964	20.2					
LCP2-0.66-100	0.66	100	295	0.33	400	1180	15.8					
LCP2-0.54-150	0.54	150	521	0.27	600	2084	16.1					
LCP2-0.44-220	0.44	220	784	0.22	880	3136	15.8					
LCP2-0.36-330	0.36	330	960	0.18	1320	3840	15.8C					
LCP3-6.64-2.2	6.64	2.2	5	3.32	8.8	20	31.7					
LCP3-4.46-4.7	4.46	4.7	12	2.23	18.8	48	32.2					
LCP3-3.00-10	3.00	10	26	1.5	40	104	32.8					
LCP3-2.42-15	2.42	15	37	1.21	60	148	31.8					
LCP3-2.00-22	2.00	22	55	1.00	88	220	32.7					
LCP3-1.62-33	1.62	33	84	0.81	132	336	32.1					
LCP3-1.34-47	1.34	47	127	0.67	188	508	32.3					
LCP3-1.12-68	1.12	68	188	0.56	272	752	32.4					
LCP3-0.94-100	0.94	100	250	0.47	400	1000	32.2					
LCP3-0.76-150	0.76	150	346	0.38	600	1384	31.8					
LCP3-0.62-220	0.62	220	478	0.31	880	1912	31.2					
LCP3-0.50-330	0.50	330	671	0.25	1320	2684	30.4					
LCP3-0.42-470	0.42	470	1003	0.21	1880	4012	30.5					
LCP3-0.36-680	0.36	680	1500	0.18	2720	6000	32.3					

THE TALEMA GROUP • World Wide Toroidal Specialists

LCP Series • Miniature High Current Toroidal Inductors

Part Number	Parallel Connected			Series Connected			Energy Storage (µJ) *	Dimensions Inches(Millimeters)				
	Full Load Current (A _{DC})	L _O (µH) ±15% No Load	DCR mOhm	Full Load Current (A _{DC})	L _O (µH) ±15% No Load	DCR mOhm		A	B	C	D	H
LCP4-7.40-2.2	7.40	2.2	5	3.70	8.8	20	0.472 (12.0)	0.472 (12.0)	0.402 (10.2)	0.082 (2.2)	0.276 (7.0)	
LCP4-4.80-4.7	4.80	4.7	9	2.40	18.8	36						
LCP4-3.36-10	3.36	10	21	1.68	40	84						
LCP4-2.80-15	2.80	15	35	1.40	60	140						
LCP4-2.30-22	2.30	22	50	1.15	88	200						
LCP4-1.86-33	1.86	33	76	0.93	132	304						
LCP4-1.56-47	1.56	47	112	0.78	188	448						
LCP4-1.32-68	1.32	68	167	0.66	272	668						
LCP4-1.06-100	1.08	100	250	0.54	400	1000						
LCP4-0.88-150	0.88	150	307	0.44	600	1228						
LCP4-0.72-220	0.72	220	470	0.36	880	1880						
LCP4-60-330	0.60	330	657	0.30	1320	2628						
LCP4-0.50-470	0.50	470	900	0.25	1880	3600						
LCP4-0.40-680	0.40	680	1355	0.20	2720	5420						
LCP4-0.34-1000	0.34	1000	2042	0.17	4000	8168						
LCP5-6.40-4.7	6.40	4.7	7	3.20	18.8	28						0.472 (12.0)
LCP5-4.50-10	4.50	10	16	2.25	40	64						
LCP5-3.50-15	3.50	15	28	1.75	60	112						
LCP5-3.00-22	3.00	22	38	1.50	88	152						
LCP5-2.44-33	2.44	33	52	1.22	132	208						
LCP5-2.04-47	2.04	47	72	1.02	188	288						
LCP5-1.70-68	1.70	68	86	0.85	272	344						
LCP5-1.40-100	1.40	100	128	0.70	400	512						
LCP5-1.16-150	1.16	150	218	0.58	600	872						
LCP5-0.94-220	0.94	220	298	0.47	880	1192						
LCP5-0.78-330	0.78	330	451	0.39	1320	1804						
LCP5-0.64-470	0.64	470	604	0.32	1880	2416						
LCP5-0.54-680	0.54	680	934	0.27	2720	3736						
LCP5-0.44-1000	0.44	1000	1629	0.22	4000	6516						
LCP5-0.36-1500	0.36	1500	2483	0.18	6000	9932						
LCP5-0.30-2200	0.30	2200	3773	0.15	8800	15092						

Talema's engineering staff can assist in the design of other inductance values and sizes.

Notes:

1. L(µH): Inductance is tested at 10mV and 10 kHz.
2. The µJoule rating ($\frac{1}{2}LI^2$) is the ability of the inductor to store energy.

Dimensions

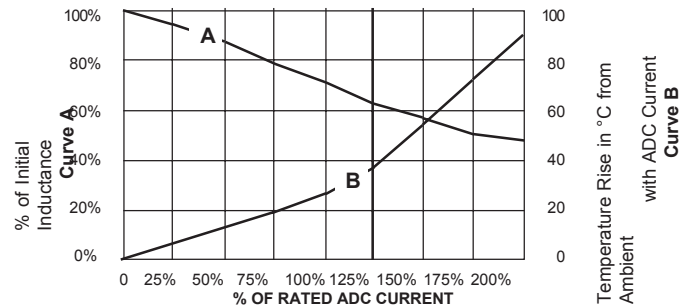
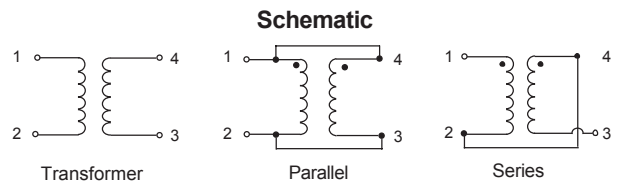
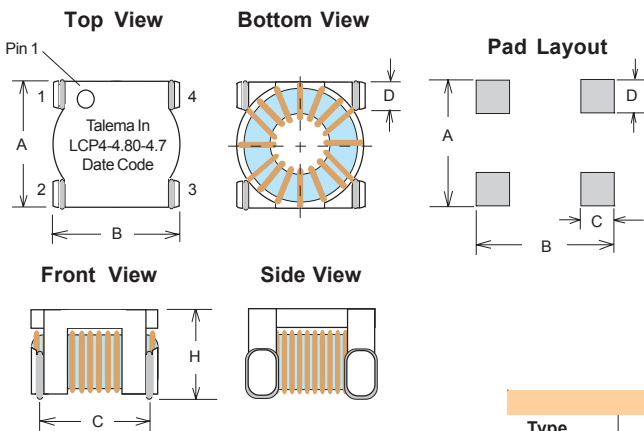

Pad Dimensions				
Type	A	B	C	D
LCP-1	8.0	7.0	2.5	2.5
LCP-2	10.0	9.0	3.0	3.0
LCP-3	12.0	11.0	3.0	3.0
LCP-4 & 5	13.0	12.0	3.5	3.5

Dimensions: Inches (Millimeters)
Tolerance: ±0.010 (0.25) unless specified otherwise
Surface Coplanarity will be <0.006(0.15)



LC Series • Miniature Low Cost Toroidal Inductors

LC Series surface mount toroidal inductors are designed for use in applications where energy storage is required for maintenance of a highly stable inductance when a rapid change in load current occurs. These inductors are excellent for filtering high frequency signals while supporting a substantial DC current as well as for AC ripple, switch mode power supplies and for use with DC-DC Converters.

Features

- Operating frequency to 1 MHz
- High energy storage with minimum saturation
- High stability from no load to full load
- Pick and place compatible
- Designed as 1:1 Coupled Inductor (Series or Parallel) or as 1:1 Isolation Transformer
- Manufactured in an ISO-9001:2000, TS-16949:2002 and ISO-14001:2004 certified Talema facility
- Meets lead free reflow level J-STD-020C
- Fully RoHS compliant



Electrical Specifications at 25°C

Test frequency: Inductance measured @ 10kHz/10mV

Test Voltage between windings: 500Vrms

Operating Temperature: -40°C to +125°C

Climatic category: IEC68-1 40/125/56

Applications

DC-DC Converters • Common Mode Filter • Computer Note Books
Pulse Modulation Switching Regulators: Step-up, Step-down,
Inverting or dual output • Filtering Battery Powered Equipment

Part Number	Parallel Connected			Series Connected			Energy Storage (μJ) ²
	Full Load Current (A _{DC})	L _O (μH) ±15% No Load	DCR mOhm	Full Load Current (A _{DC})	L _O (μH) ±15% No Load	DCR mOhm	
LC1-3.00-2.2	3.00	2.2	9	1.50	8.8	36	7.0
LC1-2.10-4.7	2.10	4.7	16	1.05	18.8	64	7.2
LC1-1.40-10	1.40	10	37	0.70	40	148	7.2
LC1 1.10-15	1.10	15	58	0.55	60	232	7.0
LC1-0.92-22	0.92	22	86	0.46	88	344	7.1
LC1-0.76-33	0.76	33	133	0.38	132	532	7.2
LC1-0.64-47	0.64	47	205	0.32	188	820	7.1
LC1-0.54-68	0.54	68	307	0.27	272	1228	7.2
LC1-0.44-100	0.44	100	376	0.22	400	1504	7.2
LC1-0.36-150	0.36	150	719	0.18	600	2876	7.2
LC1-0.30-220	0.30	220	866	0.15	880	3464	7.3

Talema's engineering staff can assist in the design of other inductance values and sizes.

Note: The μJoule rating ($\frac{1}{2}LI^2$) is the ability of the inductor to store energy.

Dimensions

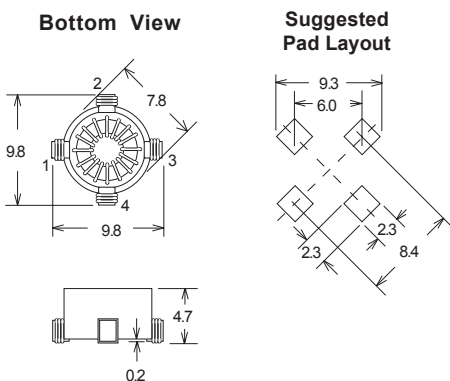

Dimensions: Inches (Millimeters)

Tolerance: ±0.010 (0.25) unless specified otherwise

Schematic

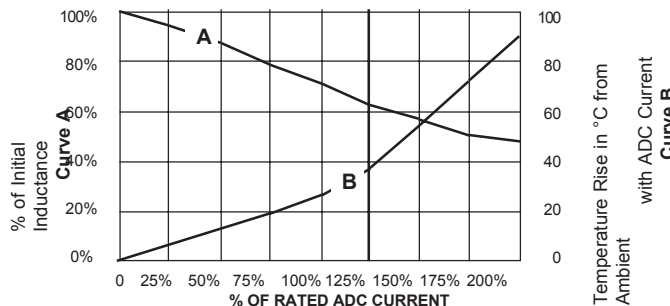
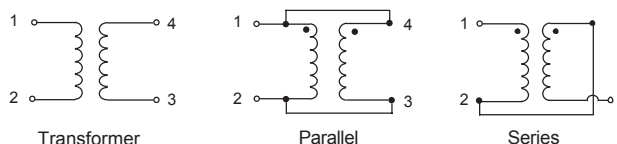

Germany: Int.+4989-841 00-0 • Ireland: Int.+35 374 - 954 8666 • Czech Rep: Int.+420 377 - 338 351 • India: Int.+91 427 - 244 1325
<http://www.talema-nuvotem.com>

DJ Series • Low Cost Linear Storage Chokes

DJ Series Storage Chokes offer high storage capacity in a compact, low cost design. Used primarily in switched-mode power supplies where low losses are essential at high pulse frequencies.

Features

- High storage capacity (to 5000μJoules) in compact size
- Low losses at high pulse frequencies
- Operating frequency to 100 kHz
- Low leakage
- Small mounting area due to vertical design
- Competitive pricing due to high volume production
- Manufactured in an ISO-9001:2000, TS-16949:2002 and ISO-14001:2004 certified Talema facility
- Fully RoHS compliant

Electrical Specifications at 25°C

Test frequency: Inductance measured @ 10kHz and 10mV

Test voltage between windings: 500Vrms

Operating temperature: -40°C to +125°C

Climatic category: IEC68-1 40/125/56



Part Number	Connection	I _{DC} Amps	L(μH) Typ. @ rated current	L _O (μH) ±15% no load	DCR (mOhm) Max.	Min. Energy Storage (μ Joule)	Wire Ø mm	Schematic	Weight per Piece
DJ-500	Series	1.5	372	600	212	419	0.56	1	18
	Parallel	3.0	93	150	53	419	0.56	1	18
DJ-501	Series	2.0	228	368	132	456	0.63	1	18
	Parallel	4.0	57	92	33	456	0.63	1	18
DJ-502	Series	2.5	140	224	80	431	0.71	1	18
	Parallel	5.0	35	56	20	431	0.71	1	18
DJ-503	Series	3.0	100	164	52	456	0.80	1	18
	Parallel	6.0	25	41	13	456	0.80	1	18
DJ-504	Series	4.6	44	72	24	477	1.00	1	19
	Parallel	9.2	11	18	6	477	1.00	1	19
DJ-1500	Series	2.0	752	1,428	180	1,501	0.80	1	56
	Parallel	4.0	188	357	45	1,501	0.80	1	56
DJ1501	Series	2.5	468	892	124	1,465	0.85	1	54
	Parallel	5.0	117	223	31	1,465	0.85	1	54
DJ-1502	Series	3.0	328	624	76	1,477	1.00	1	57
	Parallel	6.0	82	156	19	1,477	1.00	1	57
DJ-1503	Series	4.0	188	356	44	1,501	1.12	1	56
	Parallel	8.0	47	89	11	1,501	1.12	1	56
DJ-1504	Series	6.0	80	148	20	1,406	1.00	2	56
	Parallel	12.0	20	37	5	1,406	1.00	2	56
DJ-1505	Series	7.5	48	96	12	1,406	1.12	2	56
	Parallel	15.0	12	24	3	1,406	1.12	2	56
DJ-2500	Series	2.8	628	1,292	176	2,458	0.80	1	63
	Parallel	5.6	157	323	44	2,458	0.80	1	63
DJ-2501	Series	3.5	404	832	112	2,482	0.90	1	63
	Parallel	7.0	101	208	28	2,482	0.90	1	63
DJ-2502	Series	4.5	248	508	72	2,499	1.0	1	63
	Parallel	9.0	62	127	18	2,499	1.00	1	63
DJ-2503	Series	6.0	140	284	40	2,499	1.12	1	63
	Parallel	12.0	35	71	10	2,499	1.12	1	63
DJ-2504	Series	8.5	68	144	20	2,517	1.00	2	63
	Parallel	17.0	17	36	5	2,517	1.00	2	63
DJ-2505	Series	10.5	48	96	12	2,604	1.12	2	64
	Parallel	21.0	12	24	3	2,604	1.12	2	64

Notes: The μJoule rating ($\frac{1}{2}LI^2$) is the ability of the inductor to store energy.

DJA Series • High Capacity Linear Storage Chokes

Storage capacity $\frac{1}{2} LI^2 \approx 3500$ & $5000 \mu\text{Ws}$ (μ Joule)

The DJA Series utilizes Fe-based amorphous alloy cores which provide high flux density and low core loss. These storage chokes allow you to optimize your designs by giving a highly stable inductance over a wide DC bias current range at operating frequencies to 500 kHz.

Part Number	Connection	I _{DC} Amps	L (μH) Typ. @ rated current	L ₀ (μH) ±15% no load	DCR (mOhm) Max.	Min. Energy Storage (μ Joule)	Wire Ø mm	Schematic	Weight per Piece
DJA-3500	Series	3.3	624	780	128	3,392	0.80	1	33
	Parallel	6.6	156	195	32	3,392	0.80	1	33
DJA-3501	Series	4.0	420	524	92	3,355	0.85	1	33
	Parallel	8.0	105	131	23	3,355	0.85	1	33
DJA-3502	Series	5.3	236	296	48	3,314	1.00	1	33
	Parallel	10.6	59	74	12	3,314	1.00	1	33
DJA-3503	Series	6.7	148	184	32	3,319	1.12	1	33
	Parallel	13.4	37	46	8	3,319	1.12	1	33
DJA-3504	Series	9.8	68	88	16	3,324	0.95	2	33
	Parallel	19.6	17	22	4	3,324	0.95	2	33
DJA-3505	Series	11.6	50	62	12	3,335	1.06	2	33
	Parallel	23.2	12.5	15.5	3	3,335	1.06	2	33
DJA-5000	Series	4.0	636	792	124	5,079	0.85	1	44
	Parallel	8.0	159	198	31	5,079	0.85	1	44
DJA-5001	Series	5.0	408	508	80	5,079	0.95	1	44
	Parallel	10.0	102	127	20	5,079	0.95	1	44
DJA-5002	Series	6.4	248	312	44	5,079	1.12	1	44
	Parallel	12.8	62	78	11	5,079	1.12	1	44
DJA-5003	Series	8.4	144	180	26	5,054	0.90	2	44
	Parallel	16.8	36	45	6.5	5,054	0.90	2	44
DJA-5004	Series	12.3	68	84	12	5,073	1.06	2	44
	Parallel	24.6	17	21	3	5,073	1.06	2	44
DJA-5005	Series	14.5	48	60	10	5,047	1.12	2	44
	Parallel	29.0	12	15	2.5	5,047	1.12	2	44

Dimensions

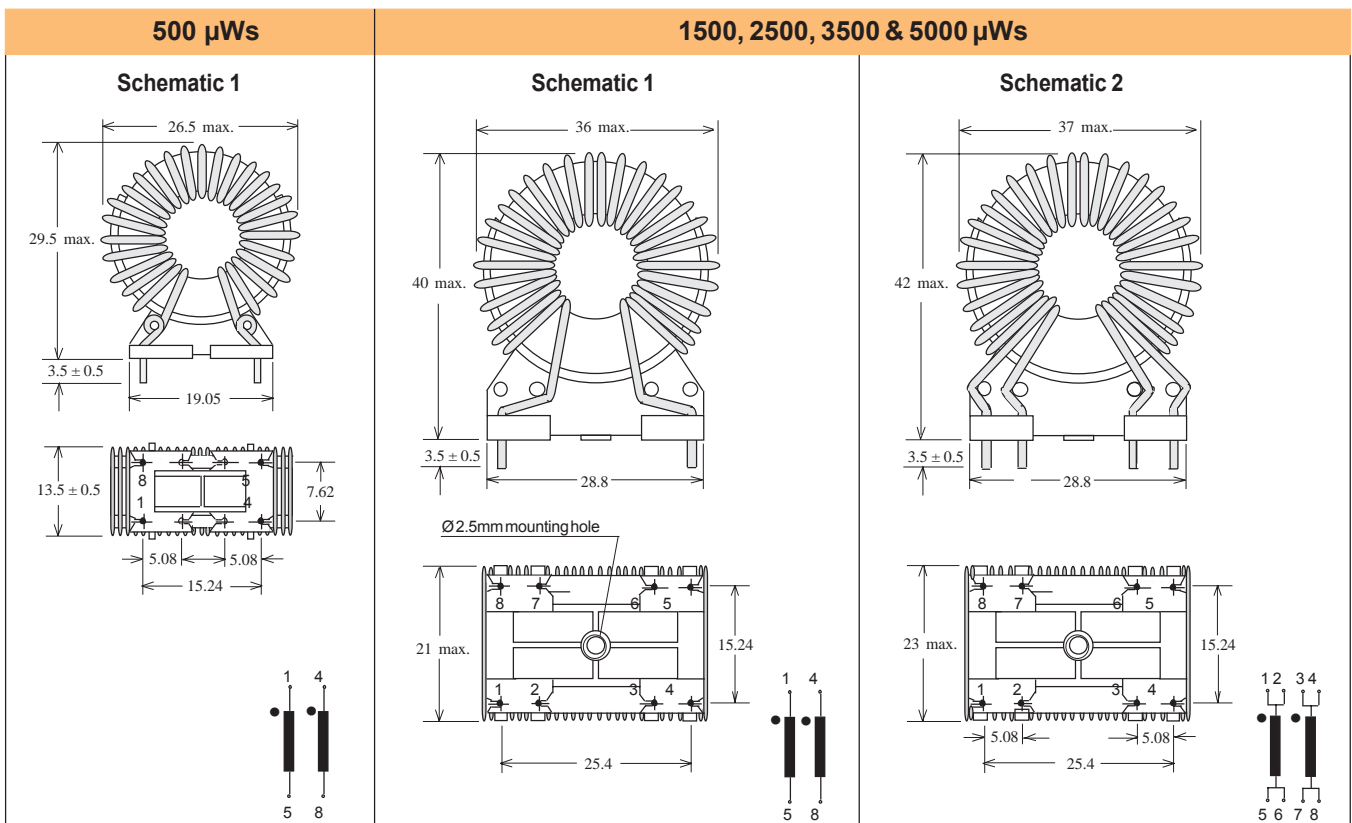

Germany: Int.+4989-841 00-0 • Ireland: Int.+35 374 - 954 8666 • Czech Rep: Int.+420 377 - 338 351 • India: Int.+91 427 - 244 1325
<http://www.talema-nuvotem.com>



DP Series • Low Cost Power Inductors

DP Series Power Inductors provide an excellent, low cost alternative to conventional chokes or inductors. Used in EMI filtering and energy storage, these compact, low radiation inductors are extremely effective in controlling AC output ripple of Switch Mode Power Supplies.

Features

- Broad range of inductance values and current ratings
- Low cost, no radiation design
- Hot Solder, pre-tinned leads for easy PC board mounting
- Operating frequency to 100kHz
- Competitive pricing due to high volume production
- Manufactured in ISO-9001:2000, TS-16949:2002 and ISO-14001:2004 certified Talema facility
- Fully RoHS compliant

Electrical Specifications @ 25°C

Test frequency: Inductance measured @ 10kHz/10mV

Test voltage between windings: 500Vrms

Operating temperature: -40°C to +125°C

Climatic category: IEC68-1 40/125/56



Applications

Switching Power Supplies • EMI/RFI filtering • Output Chokes

Part Number	I _{bc} Amps	L(μH) Typ. @ Rated Current	L ₀ (μH) ±15% No Load	DCR (Ohms Max.)	Min. Energy Storage (μJ)*	Wire Ø (mm)	Coil Size mm OD x Ht.	Mounting Style Availability / Size			
								C	B	V	F
DP__-0.5-47	0.5	47	50	0.095	5.9	0.400	14 X 8	2	3	2	2
DP__-0.5-68		68	73	0.115	8.5	0.400	14 X 8	2	3	2	2
DP__-0.5-100		100	109	0.140	12.5	0.400	14 X 8	2	3	2	2
DP__-0.5-150		150	167	0.173	18.8	0.400	15 X 8	2	3	2	2
DP__-0.5-220		220	258	0.215	27.5	0.400	15 X 9	2	3	2	2
DP__-0.5-330		330	393	0.265	41.3	0.400	15 X 9	2	3	2	2
DP__-0.5-470		470	557	0.322	58.8	0.400	20 X 9	3	3	3	3
DP__-0.5-680		680	849	0.398	85	0.400	20 X 10	3	3	3	3
DP__-0.5-1000		1,000	1,358	0.503	125	0.400	21 X 11	3	5	4	3
DP__-0.5-1500		1,500	1,863	0.714	188	0.400	25 X 12	5	5	4	4
DP__-0.5-2200		2,200	3,131	0.926	275	0.400	25 X 12	5	5	4	4
DP__-0.5-3300		3,300	5,024	1.173	413	0.400	26 X 13	5	5	5	6
DP__-0.5-4700		4,700	6,287	1.421	588	0.400	32 X 15	5	8	5	6
DP__-1.0-22		1.0	22	23	0.041	11	0.500	14 X 8	2	3	2
DP__-1.0-33	33		37	0.052	16.5	0.500	14 X 8	2	3	2	2
DP__-1.0-47	47		53	0.063	23.5	0.500	14 X 8	2	3	2	2
DP__-1.0-68	68		80	0.077	34	0.500	14 X 8	2	3	2	2
DP__-1.0-100	100		127	0.097	50	0.500	15 X 8	2	3	2	2
DP__-1.0-150	150		207	0.123	75	0.500	15 X 9	2	3	3	2
DP__-1.0-220	220		345	0.196	110	0.450	15 X 9	2	3	3	2
DP__-1.0-330	330		491	0.193	165	0.500	20 X 9	3	3	3	3
DP__-1.0-470	470		601	0.180	235	0.600	27 X 12	5	5	5	6
DP__-1.0-680	680		891	0.220	340	0.600	27 X 13	5	5	5	6
DP__-1.0-1000	1,000		1,619	0.426	500	0.500	26 X 13	4	5	5	6
DP__-1.0-1500	1,500		2,149	0.532	750	0.500	30 X 14	5	5	5	6
DP__-1.0-2200	2,200		3,609	0.689	1100	0.500	31 X 15	5	5	6	6
DP__-1.0-3300	3,300		4,731	0.609	1650	0.600	43 X 15	--	8	--	--

Note: The μJoule rating (0.5 x LI²) is the ability of the inductor to store energy.

DP Series • Low Cost Power Inductors

Electrical Specifications at 25 °C

Part Number	I _{DC} Amps	L (μH) Typ. @ Rated Current	L ₀ (μH) ±15% No Load	DCR (Ohms Max.)	Min Energy Storage (μJ)*	Wire Ø (mm)	Coil Size mm O.D. x Ht.	Mounting Style Availability / Size			
								C	B	V	F
DP__-2.0-22	2.0	22	27	0.070	44	0.400	14 x 8	2	3	2	2
DP__-2.0-33		33	45	0.089	66	0.400	14 x 8	2	3	2	2
DP__-2.0-47		47	73	0.090	94	0.450	15 x 8	2	3	2	2
DP__-2.0-68		68	109	0.089	136	0.500	15 x 8	2	3	2	2
DP__-2.0-100		100	157	0.109	200	0.500	19 x 8	3	3	3	3
DP__-2.0-150		150	207	0.106	300	0.600	25 x 12	4	5	4	4
DP__-2.0-220		220	328	0.153	440	0.560	25 x 11	4	5	4	4
DP__-2.0-330		330	575	0.202	660	0.560	26 x 12	4	5	4	4
DP__-2.0-470		470	720	0.214	940	0.600	30 x 14	5	5	5	6
DP__-2.0-680		680	1,251	0.282	1,360	0.600	30 x 14	5	5	5	6
DP__-2.0-1000		1000	1,429	0.335	2,000	0.600	42 x 14	--	5	9	--
DP__-2.0-1500		1500	2,488	0.441	3,000	0.600	42 x 15	--	8	9	--
DP__-2.0-2200		2200	3,218	0.405	4,400	0.710	51 x 22	--	10	--	--
DP__-3.0-15	3.0	15	21	0.039	68	0.500	14 x 8	2	3	2	2
DP__-3.0-22		22	34	0.050	99	0.500	14 x 8	2	3	2	2
DP__-3.0-33		33	49	0.038	149	0.630	19 x 8	3	3	3	3
DP__-3.0-47		47	75	0.048	212	0.630	20 x 8	3	3	3	3
DP__-3.0-68		68	92	0.060	306	0.630	25 x 12	4	5	4	4
DP__-3.0-100		100	157	0.080	458	0.630	25 x 12	4	5	4	4
DP__-3.0-150		150	256	0.107	675	0.630	25 x 12	4	5	4	4
DP__-3.0-220		220	346	0.134	990	0.630	29 x 13	5	5	5	6
DP__-3.0-330		330	625	0.142	1,485	0.710	30 x 14	5	5	5	6
DP__-3.0-470		470	727	0.187	2,115	0.670	42 x 14	--	5	9	--
DP__-3.0-680		680	1,124	0.302	3,060	.0630	42 x 16	--	8	--	--
DP__-3.0-1000		1000	1,493	0.304	4,500	0.670	49 x 20	--	10	--	--
DP__-3.0-1500		1500	2,324	0.384	6,750	0.670	53 x 24	--	11	--	--
DP__-3.0-2200	2200	4,090	0.509	9,900	0.670	54 x 26	--	11	--	--	
DP__-5.0-15	5.0	15	23	0.029	188	0.600	20 x 8	3	3	3	3
DP__-5.0-22		22	28	0.039	275	0.600	25 x 12	4	5	4	4
DP__-5.0-33		33	48	0.036	413	0.710	25 x 12	4	5	4	4
DP__-5.0-47		47	82	0.043	588	0.750	25 x 12	4	5	4	4
DP__-5.0-68		68	137	0.055	850	0.750	26 x 12	4	5	4	4
DP__-5.0-100		100	172	0.059	1,250	0.800	30 x 13	5	5	5	6
DP__-5.0-150		150	221	0.094	1,875	0.710	41 x 13	--	5	9	--
DP__-5.0-220		220	381	0.097	2,750	0.800	41 x 13	--	5	9	--
DP__-5.0-330		330	475	0.156	4,125	0.710	49 x 20	--	10	--	--
DP__-5.0-470		470	852	0.187	5,875	0.750	49 x 20	--	10	--	--
DP__-5.0-680		680	1,186	0.196	8,500	0.800	53 x 25	--	11	--	--
DP__-5.0-1000	1000	2,093	0.206	12,500	0.900	55 x 26	--	11	--	--	
DP__-7.5-15	7.5	15	18	0.022	422	0.750	30 x 14	5	5	5	6
DP__-7.5-22		22	30	0.025	619	0.800	30 x 14	5	5	5	6
DP__-7.5-33		33	49	0.025	928	0.900	30 x 14	5	5	5	6
DP__-7.5-47		47	84	0.026	1,322	1.000	31x 14	5	5	5	6
DP__-7.5-68		68	105	0.040	1,913	0.900	42 x 14	--	5	9	--
DP__-7.5-100		100	160	0.045	2,813	1.000	43 x 17	--	8	--	--
DP__-7.5-150		150	219	0.074	4,219	0.850	50 x 21	--	10	--	--
DP__-7.5-220		220	373	0.070	6,188	1.000	51 x 22	--	10	--	--
DP__-7.5-330		330	605	0.090	9,281	1.000	54 x 25	--	11	--	--
DP__-7.5-470	470	1,054	0.085	13,219	1.180	55 x 28	--	11	--	--	

Germany: Int.+4989-841 00-0 • Ireland: Int.+35 374 - 954 8666 • Czech Rep: Int.+420 377 - 338 351 • India: Int.+91 427 - 244 1325
<http://www.talema-nuvotem.com>



DP Series • Low Cost Power Inductors

Part Number	I _{dc} Amps	L (μH) Typ. @ Rated Current	L ₀ (μH) ±15% No Load	DCR (Ohms Max.)	Min. Energy Storage (μJ)*	Wire Ø mm	Coil size mm O.D. x Ht.	Mounting Style Availability / Size			
								C	B	V	F
DP__-10-15	10	15	21	0.013	750	1.000	30 X 14	5	5	5	6
DP__-10-22		22	28	0.021	1,100	0.900	41 X 14	--	5	9	--
DP__-10-33		33	46	0.022	1,650	1.000	42 X 14	--	5	9	--
DP__-10-47		47	75	0.028	2,350	1.000	42 X 14	--	5	9	--
DP__-10-68		68	89	0.042	3,400	0.900	50 X 21	--	10	--	--
DP__-10-100		100	152	0.044	5,000	1.000	50 X 21	--	10	--	--
DP__-10-150		150	248	0.041	7,500	1.180	55 X 26	--	11	--	--
DP__-10-220		220	427	0.054	11,000	1.180	55 X 26	--	11	--	--
DP__-15-6.8	15	6.8	8	0.009	765	1.000	41 X 14	--	5	9	--
DP__-15-10		10	14	0.012	1,125	1.000	41 X 14	--	5	9	--
DP__-15-15		15	22	0.011	1,688	1.180	41 X 14	--	5	9	--
DP__-15-22		22	36	0.014	2,475	1.250	44 X 18	--	8	--	--
DP__-15-33		33	49	0.018	3,713	1.180	50 X 21	--	10	--	--
DP__-15-47		47	75	0.016	5,288	1.400	51 X 22	--	11	--	--
DP__-15-68		68	123	0.018	7,650	1.500	52 X 23	--	11	--	--
DP__-15-100		100	207	0.023	11,250	1.500	56 X 27	--	11	--	--

Talema's engineering staff can assist in the design of other inductance values and sizes.

Notes

- 1) The μJoule rating ($0.5 \times LI^2$) is the ability of the inductor to store energy.
- 2) Inductance is measured at 0.10Vrms @ 10kHz without DC Current and 0.25 Vrms @ 10kHz with DC Current.

Ordering Key

DP O - 0.5 - 470 μH

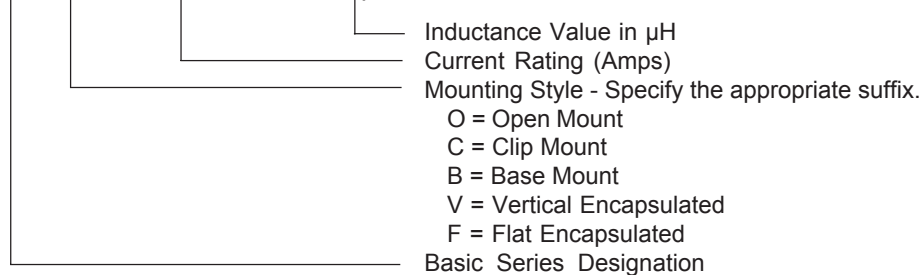

Sales & Marketing, Design and Manufacturing Facilities

<http://www.talema-nuvotem.com>

Eastern Europe & Czech Republic

NT MAGNETICS s.r.o.
 Chebská 27
 322 00 Plzeň
 Tel: Int. + 420 377 - 338 351
 Fax: Int. + 420 377 - 338 350
 Email: talema@talema.cz
 Web Site: www.ntmagnetics.cz

Germany

TALEMAELEKTRONIK GMBH
 Sembdnerstr. 5, Postfach 2523
 82110 Germering
 Tel: Int. + 49 89 - 841 00 - 0
 Fax: Int. + 49 89 - 841 00 25
 Email: info@talema.de

Ireland

NUVOTEMTEO.
 Crollý
 Co. Donegal
 Tel: Int. + 353 74 - 954 8666
 Fax: Int. + 353 74 - 954 8139
 Email: info@nuvotem.com

India

TALEMA ELECTRONIC PVT. LTD.
 Opposite the SIDCO Industrial Estate
 Gins Towers
 4/5S.H/1, Omalur Main Road
 Salem - 636 004, Tamil Nadu
 Tel: Int. + 91 427 - 244 1325
 Fax: Int. + 91 427 - 243 0034
 E-mail: talema@talemaindia.com
 Web Site: www.talemaindia.com

Mounting Styles • DP Series - Low Cost Power Inductors

Base Mount

Type O - Open Mount

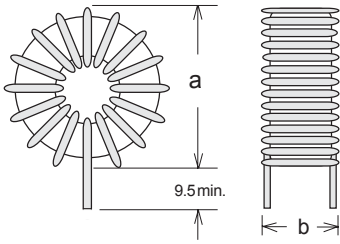

Type B-I

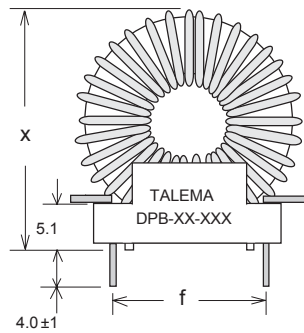

Type B-II

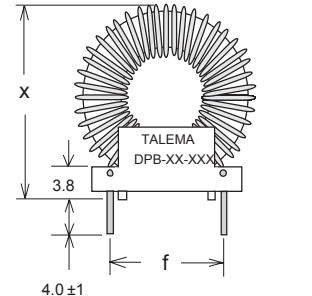

Type C - Clip Mount

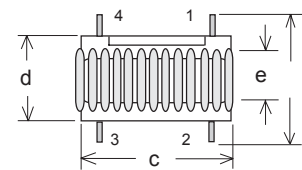
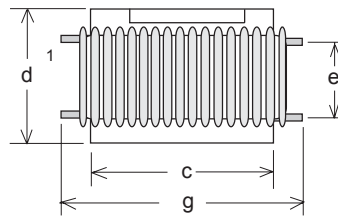
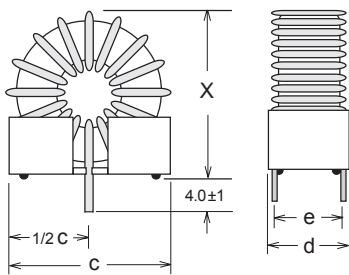

Type V - Vertical Mount

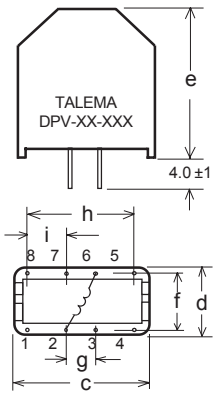

Type F - Flat Mount

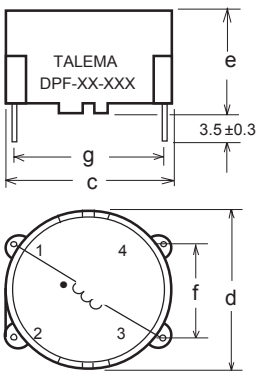

Mounting Style	Size Code	Dimensions (mm)								Pin Ø
		c	d	e	f	g	h	i	x	
"C" Clip Mount	2	16.5	11.4	7.6	--	--	--	--	Coil O.D. + 2.8	See Data Page
	3	21.0	11.4	7.6	--	--	--	--	Coil O.D. + 2.8	
	4	24.1	15.2	11.4	--	--	--	--	Coil O.D. + 2.8	
	5	31.8	17.8	12.7	--	--	--	--	Coil O.D. + 3.3	
"V" Vertical Mount	2	17.8	12.8	20.0	10.0	5.0	15.0	5.0	--	0.60 x 0.88
	3	23.0	15.5	25.0	12.5	10.0	20.0	5.0	--	
	4	27.0	18.0	30.0	15.0	12.5	22.5	5.0	--	
	5	32.0	20.5	35.0	17.5	12.5	27.5	7.5	--	
	6	32.0	23.0	35.0	20.0	12.5	27.5	7.5	--	
"F" Flat Mount	2	17.5	17.0	12.5	10.0	15.0	--	--	--	0.60 x 0.88
	3	22.5	22.0	15.0	12.5	20.0	--	--	--	
	4	27.5	27.0	17.5	15.0	25.0	--	--	--	
	6	32.5	32.0	20.0	20.0	30.0	--	--	--	
Base Mount "B-I"	5	25.4	15.2	10.2	20.3	34.3	--	--	Coil O.D. + 3.5	1.27
	8	27.9	20.3	15.2	22.9	36.8	--	--		
	10	35.6	22.9	17.8	30.5	44.5	--	--		
"B-II"	3	19.1	10.8	6.4	15.2	15.9	--	--	Coil O.D. + 3.8	1.02



SA Series • High Efficiency - High Stability Storage Chokes

SA Series storage chokes have been designed with Fe-based amorphous alloy which provides high flux density and low core loss which is ideal for optimizing choke design. Providing exceptional efficiency and field modulation when used as loading coils for interim energy storage with SMPS, the use of amorphous cores gives a highly stable inductance over a wide DC bias current range and high "Q" with operating frequencies to 500kHz.

Features

- Fe-based amorphous alloy cores
- Operating frequencies to 500kHz
- Small size and high "Q"
- Highly stable inductance with changing DC bias current
- Low temperature rise
- Fully encapsulated styles available meeting class GFK (-40°C to +125°C, humidity class F) per DIN 40040
- Manufactured in ISO-9001:2000, TS-16949:2002 and ISO-14001:2004 certified Talema facility
- Fully RoHS compliant

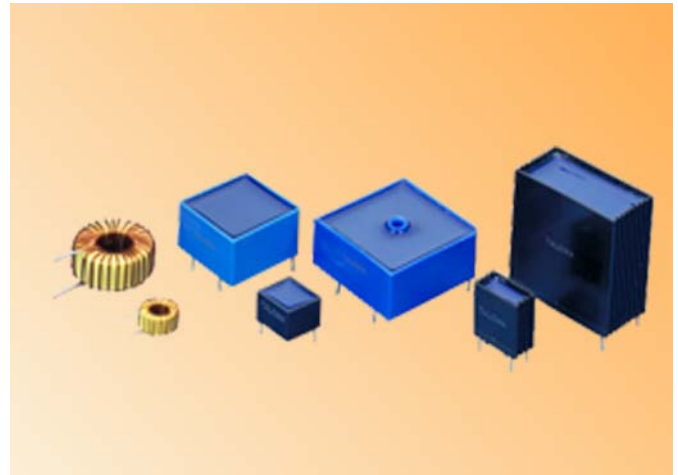

Electrical Specifications @ 25°C

Test frequency: Inductance measured @ 10kHz / 10mV

Test voltage between windings: 500Vrms

Operating temperature: -40°C to +125°C

Climatic category: IEC68-1 40/125/56

Part Number	I _{dc} Amps	L (µH) Typ. @ Rated Current	L ₀ (µH) ±25% No Load	DCR mOhms Typical	Energy Storage (µJ) *	Schematic	Coil Size O.D. x Ht. (a x b)	Housing Size Code		Mounting Style (Terminal Ød)		
								F	V	O	F	V
SA_-0.63-22	0.63	22	23	95	4	1	12 x 8	17	20	0.355	0.60	0.80
SA_-0.63-33		33	35	118	7	1	12 x 8	17	20	0.355	0.60	0.80
SA_-0.63-47		47	49	141	10	1	13 x 9	17	20	0.355	0.60	0.80
SA_-0.63-68		68	70	167	13	1	13 x 9	17	20	0.355	0.60	0.80
SA_-0.63-100		100	105	206	20	1	13 x 9	17	20	0.355	0.60	0.80
SA_-0.63-150		150	157	276	29	1	13 x 9	17	20	0.335	0.60	0.80
SA_-0.63-220		220	248	348	44	1	14 x 9	17	20	0.335	0.60	0.80
SA_-0.63-330		330	389	436	65	1	14 x 9	17	20	0.335	0.60	0.80
SA_-0.63-470		470	480	421	92	1	16 x 8	22	20	0.335	0.60	0.80
SA_-0.63-680		680	728	519	136	1	17 x 9	22	25	0.335	0.60	0.80
SA_-0.63-1000		1000	1105	639	197	1	17 x 9	22	25	0.335	0.60	0.80
SA_-0.63-1500		1500	1523	801	299	1	22 x 8	29	30	0.335	0.60	0.80
SA_-0.63-2200		2200	2249	974	437	1	23 x 9	29	30	0.335	0.60	0.80
SA_-0.63-3300		3300	3514	1217	655	1	24 x 10	29	30	0.335	0.60	0.80
SA_-0.63-4700		4700	5345	1501	933	1	24 x 10	29	30	0.335	0.60	0.80
SA_-0.63-6800		6800	6949	2003	1351	1	27 x 16	32	35	0.335	0.60	0.80
SA_-0.63-8200	8200	9057	2287	1618	1	28 x 17	32	40	0.335	0.60	0.80	
SA_-1.0-22	1.0	22	23	59	11	1	12 x 8	17	20	0.450	0.60	0.80
SA_-1.0-33		33	35	73	17	1	12 x 8	17	20	0.450	0.60	0.80
SA_-1.0-47		47	49	88	23	1	13 x 9	17	25	0.450	0.60	0.80
SA_-1.0-68		68	73	107	34	1	13 x 9	17	25	0.450	0.60	0.80
SA_-1.0-100		100	102	110	51	1	16 x 9	22	25	0.450	0.60	0.80
SA_-1.0-150		150	151	134	74	1	16 x 9	22	25	0.450	0.60	0.80
SA_-1.0-220		220	230	165	110	1	16 x 9	22	25	0.450	0.60	0.80
SA_-1.0-330		330	362	207	167	1	18 x 10	22	25	0.450	0.60	0.80
SA_-1.0-470		470	472	252	236	1	22 x 9	29	25	0.450	0.60	0.80
SA_-1.0-680		680	698	307	342	1	24 x 10	29	25	0.450	0.60	0.80
SA_-1.0-1000		1000	1031	373	500	1	24 x 10	29	30	0.450	0.60	0.80
SA_-1.0-1500		1500	1641	470	746	1	24 x 10	29	30	0.450	0.60	0.80
SA_-1.0-2200		2200	2589	591	1100	1	25 x 11	29	30	0.450	0.60	0.80
SA_-1.0-3300		3300	3359	788	1646	1	28 x 17	32	40	0.450	0.60	0.80
SA_-1.0-4700		4700	4968	958	2360	1	28 x 17	32	40	0.450	0.60	0.80
SA_-1.0-6800		6800	8000	1215	3400	1	29 x 18	32	40	0.450	0.60	0.80

Talema's engineering staff can assist in the design of other inductance values and sizes.

SA Series • High Efficiency - High Stability Storage Chokes

Electrical Specifications at 25°C

Part Number	I _{DC} Amps	L (μH) Typ. @ Rated Current	L _O (μH) ±25% No Load	DCR mOhms Typical	Energy Storage (μJ) *	Schematic	Coil Size O.D. x Ht. (a x b)	Housing Size Code		Mounting Style Terminal Ød			
								F	V	O	F	V	
SA_-1.6-22	1.6	22	23	38	27	1	13 x 8	17	20	0.560	0.560	0.800	
SA_-1.6-33		33	27	49	42	1	14x 9	17	25	0.560	0.560	0.800	
SA_-1.6-47		47	55	60	59	1	14 x 9	17	25	0.560	0.560	0.800	
SA_-1.6-68		68	67	57	84	1	17 x 9	22	25	0.560	0.560	0.800	
SA_-1.6-100		100	107	73	130	1	17 x 9	22	25	0.560	0.560	0.800	
SA_-1.6-150		150	169	91	195	1	17 x 9	22	25	0.560	0.560	0.800	
SA_-1.6-220		220	268	115	278	1	18 x 11	22	25	0.560	0.560	0.800	
SA_-1.6-330		330	343	139	426	1	23 x 9	29	25	0.560	0.560	0.800	
SA_-1.6-470		470	516	170	608	1	23 x 9	29	25	0.560	0.560	0.800	
SA_-1.6-680		680	765	207	872	1	24 x 11	29	30	0.560	0.560	0.800	
SA_-1.6-1000		1000	1300	165	1272	1	27 x 16	32	35	0.560	0.560	0.800	
SA_-1.6-1500		1500	1549	345	1923	1	27 x 16	32	35	0.560	0.560	0.800	
SA_-1.6-2200		2200	2402	430	2929	1	28 x 17	32	40	0.560	0.560	0.800	
SA_-1.6-3300		3300	3458	565	4205	1	33 x 17	42	40	0.560	0.560	0.800	
SA_-1.6-4700		4700	4968	718	6041	1	43 x 16	49	45	0.560	0.560	0.800	
SA_-1.6-5600		5600	6216	804	7161	1	45 x 18	49	--	0.560	0.560	--	
SA_-2.0-22	2.0	22	23	27	46	1	15 x 8	17	20	0.630	0.630	0.630	
SA_-2.0-33		33	33	32	65	1	15 x 8	17	20	0.630	0.630	0.630	
SA_-2.0-47		47	49	39	83	1	15 x 8	17	20	0.630	0.630	0.630	
SA_-2.0-68		68	75	48	137	1	15 x 8	17	20	0.630	0.630	0.630	
SA_-2.0-100		100	112	59	200	1	16 x 9	22	20	0.630	0.630	0.630	
SA_-2.0-150		150	195	76	302	1	16 x 9	22	20	0.630	0.630	0.630	
SA_-2.0-220		220	234	91	446	1	23 x 10	29	30	0.630	0.630	0.630	
SA_-2.0-330		330	362	113	658	1	25 x 11	29	30	0.630	0.630	0.630	
SA_-2.0-470		470	551	139	947	1	25 x 11	29	30	0.630	0.630	0.630	
SA_-2.0-680		680	701	184	1374	1	27 x 16	32	35	0.630	0.630	0.630	
SA_-2.0-1000		1000	1060	226	2014	1	29 x 18	32	40	0.630	0.630	0.630	
SA_-2.0-1500		1500	1693	285	3013	1	29 x 17	32	40	0.630	0.630	0.630	
SA_-2.0-2200		2200	2500	379	4401	1	35 x 19	49	45	0.630	0.630	0.630	
SA_-2.0-3300		3300	3594	483	6612	1	46 x 19	49	--	0.630	0.630	--	
SA_-2.0-3900		3900	4567	544	7855	1	46 x 19	49	--	0.630	0.630	--	
SA_-2.5-22		2.5	22	23	23	70	1	16 x 8	22	20	0.670	0.670	0.670
SA_-2.5-33	33		33	28	101	1	16 x 8	22	20	0.670	0.670	0.670	
SA_-2.5-47	47		52	35	150	1	18 x 10	22	25	0.670	0.670	0.670	
SA_-2.5-68	68		75	42	209	1	18 x 10	22	25	0.670	0.670	0.670	
SA_-2.5-100	100		123	53	307	1	18 x 10	22	25	0.670	0.670	0.670	
SA_-2.5-150	150		159	65	476	1	23 x 10	32	30	0.670	0.670	0.670	
SA_-2.5-220	220		242	80	688	1	23 x 10	32	30	0.670	0.670	0.670	
SA_-2.5-330	330		381	100	1023	1	23 x 10	32	30	0.670	0.670	0.670	
SA_-2.5-470	470		476	131	1459	1	27 x 16	32	35	0.670	0.670	0.670	
SA_-2.5-680	680		720	161	2138	1	27 x 16	32	35	0.670	0.670	0.670	
SA_-2.5-1000	1000		1107	200	3114	1	29 x 18	32	40	0.670	0.670	0.670	
SA_-2.5-1500	1500		1786	278	4743	1	34 x 18	42	40	0.670	0.670	0.670	
SA_-2.5-2200	2200		2441	345	6867	1	43 x 16	49	--	0.670	0.670	--	
SA_-2.5-2700	2700		3295	401	8444	1	43 x 16	49	--	0.670	0.670	--	
SA_-3.15-22	3.15		22	23	19	107	1	16 x 8	22	20	0.750	0.750	0.750
SA_-3.15-33			33	36	24	164	1	18 x 10	22	25	0.750	0.750	0.750
SA_-3.15-47		47	56	29	238	1	18 x 10	22	25	0.750	0.750	0.750	
SA_-3.15-68		68	71	35	346	1	22 x 8	29	25	0.750	0.750	0.750	
SA_-3.15-100		100	103	42	488	1	24 x 10	29	30	0.750	0.750	0.750	
SA_-3.15-150		150	165	54	736	1	24 x 10	29	30	0.750	0.750	0.750	
SA_-3.15-220		220	266	68	1107	1	24 x 10	29	30	0.750	0.750	0.750	
SA_-3.15-330		330	333	89	1619	1	28 x 17	32	40	0.750	0.750	0.750	
SA_-3.15-470		470	492	108	2319	1	28 x 17	32	40	0.750	0.750	0.750	
SA_-3.15-680		680	799	138	3369	1	28 x 17	32	40	0.750	0.750	0.750	
SA_-3.15-1000		1000	1265	190	5020	1	35 x 19	42	40	0.750	0.750	0.750	
SA_-3.15-1500		1500	1656	231	7393	1	44 x 17	49	--	0.750	0.750	--	

How To Order: Refer to SD Series data sheet for Ordering Key

Germany: Int.+4989-841 00-0 • Ireland: Int.+35 374 - 954 8666 • Czech Rep: Int.+420 377 - 338 351 • India: Int.+91 427 - 244 1325
<http://www.talema-nuvotem.com>

SA Series • High Efficiency • High Stability Storage Chokes

Electrical Specifications at 25°C

Part Number	I _{DC} Amps	L (µH) Typ. @ Rated Current	L _O (µH) ±25% No Load	DCR mOhms Typical	Energy Storage (µJ) *	Schematic	Coil Size O.D. x Ht. (a x b)	Housing Size Code		Mounting Style Terminal Ød			
								F	V	O	F	V	
SA_-4.0-22	4.0	22	23	15	155	1	16 X 8	22	20	0.850	0.850	0.850	
SA_-4.0-33		33	39	19	260	1	18 x 11	22	25	0.850	0.850	0.850	
SA_-4.0-47		47	48	22	375	1	22 x 9	29	25	0.850	0.850	0.850	
SA_-4.0-68		68	75	28	556	1	24 x 11	29	30	0.850	0.850	0.850	
SA_-4.0-100		100	113	35	812	1	24 x 11	29	30	0.850	0.850	0.850	
SA_-4.0-150		150	157	48	1242	1	26 x 15	32	35	0.850	0.850	0.850	
SA_-4.0-220		220	226	57	1752	1	28 x 17	32	40	0.850	0.850	0.850	
SA_-4.0-330		330	360	72	2646	1	28 x 17	32	40	0.850	0.850	0.850	
SA_-4.0-400		400	476	83	3239	1	28 x 17	32	40	0.850	0.850	0.850	
SA_-4.0-470		470	508	94	3738	1	33 x 17	42	40	0.850	0.850	0.850	
SA_-4.0-680		680	703	117	5515	1	44 x 17	49	--	0.850	0.850	--	
SA_-4.0-1000		1000	1191	153	8006	1	44 x 17	49	--	0.850	0.850	--	
SA_-5.0-22	5.0	22	28	13	281	1	19 x 11	22	25	0.950	0.950	0.950	
SA_-5.0-33		33	35	15	430	1	22 x 9	29	25	0.950	0.950	0.950	
SA_-5.0-47		47	51	19	596	1	22 x 9	29	25	0.950	0.950	0.950	
SA_-5.0-68		68	75	23	831	1	25 x 11	29	30	0.950	0.950	0.950	
SA_-5.0-100		100	100	31	1242	1	26 x 15	32	35	0.950	0.950	0.950	
SA_-5.0-150		150	157	38	1882	1	26 x 15	32	35	0.950	0.950	0.950	
SA_-5.0-220		220	237	47	2722	1	29 x 18	32	40	0.950	0.950	0.950	
SA_-5.0-330		330	362	63	4068	1	34 x 18	42	40	0.950	0.950	0.950	
SA_-5.0-470		470	492	78	5955	1	42 x 15	49	45	0.950	0.950	0.950	
SA_-5.0-630		630	703	94	7914	1	45 x 18	49	--	0.950	0.950	--	
SA_-5.0-680		680	845	103	8554	1	45 x 18	49	--	0.950	0.950	--	
SA_-6.3-22		6.3	22	24	9	450	1	23 x 9	29	25	1.120	1.120	1.120
SA_-6.3-33	33		35	11	635	1	23 x 9	29	25	1.120	1.120	1.120	
SA_-6.3-47	47		55	14	959	1	26 x 12	29	30	1.120	1.120	1.120	
SA_-6.3-68	68		68	18	1317	1	27 x 16	32	35	1.120	1.120	1.120	
SA_-6.3-100	100		108	23	2051	1	27 x 16	32	35	1.120	1.120	1.120	
SA_-6.3-150	150		166	28	2963	1	30 x 19	32	40	1.120	1.120	1.120	
SA_-6.3-220	220		251	38	4435	1	35 x 19	42	40	1.120	1.120	1.120	
SA_-6.3-330	330		357	48	6587	1	43 x 16	49	45	1.120	1.120	1.120	
SA_-6.3-390	390		459	55	7842	1	46 x 19	49	--	1.120	1.120	--	
SA_-8.0-22	8.0		22	24	7	695	1	23 x 10	29	30	1.250	1.250	1.250
SA_-8.0-33		33	38	9	1037	1	26 x 13	29	30	1.250	1.250	1.250	
SA_-8.0-47		47	47	12	1434	1	27 x 16	32	35	1.250	1.250	1.250	
SA_-8.0-68		68	74	15	2241	1	27 x 16	32	35	1.250	1.250	1.250	
SA_-8.0-100		100	123	20	3188	1	30 x 19	32	40	1.250	1.250	1.250	
SA_-8.0-150		150	179	26	4698	1	35 x 19	42	40	1.250	1.250	1.250	
SA_-8.0-220		220	244	32	7107	1	43 x 16	49	45	1.250	1.250	1.250	
SA_-8.0-270		270	330	37	8554	1	46 x 19	49	--	1.250	1.250	--	
SA_-10-22		10	22	22	7	1060	1	27 x 16	32	40	1.320	1.320	1.320
SA_-10-33			33	33	9	1589	1	27 x 16	32	40	1.320	1.320	1.320
SA_-10-47	47		51	11	2406	1	27 x 16	32	40	1.320	1.320	1.320	
SA_-10-68	68		80	14	3280	1	27 x 16	32	40	1.320	1.320	1.320	
SA_-10-100	100		127	19	5079	1	34 x 18	42	40	1.320	1.320	1.320	
SA_-10-150	150		171	24	7442	1	43 x 16	49	--	1.320	1.320	--	
SA_-10-180	180		233	27	8876	1	43 x 16	49	--	1.320	1.320	--	
SA_-16-22	16		22	29	5	2986	2P	30 x 19	32	40	1.180	1.180	1.180
SA_-16-33		33	36	6	4128	2P	35 x 19	42	40	1.180	1.180	1.180	
SA_-16-47		47	70	10	7150	2P	43 x 16	49	45	1.180	1.180	1.180	
SA_-16-68		68	83	10	8554	2P	43 x 16	49	45	1.180	1.180	1.180	
SA_-20-10	20	10	10	3	2011	2P	27 x 16	32	40	1.320	1.320	1.320	
SA_-20-22		22	24	4	4278	2P	32 x 16	42	40	1.320	1.320	1.320	
SA_-20-33		33	38	6	6867	2P	43 x 16	49	--	1.320	1.320	--	
SA_-20-47		47	53	7	8976	2P	43 x 16	49	--	1.320	1.320	--	

Notes:

- 1) The µJoule rating ($\frac{1}{2}LI^2$) is the ability of the inductor to store energy.
- 2) Inductance measured at 0.10 Vrms @ 10kHz without DC Current and 0.25 Vrms @ 10kHz with DC Current.
- 3) On larger units and units wound with finer wire additional mechanical mounting is recommended. See page 26 for Mounting Options.



SD Series • High Efficiency Storage Chokes

SD Series storage chokes provide excellent efficiency and field modulation when used as loading coils for interim energy storage with switch mode power supplies. The use of MPP cores allows compact size, a highly stable inductance over a wide bias current range and high "Q" with operating frequencies to 200kHz.

Features

- Operating frequency to 200kHz
- Small size and high "Q"
- Highly stable inductance with changing bias current
- Fully encapsulated styles available meeting class GFK (-40°C to +125°C, humidity class F) per DIN 40040.
- Manufactured in ISO-9001:2000, TS-16949:2002 and ISO-14001:2004 certified Talema facility
- Fully RoHS compliant



Electrical Specifications @ 25°C

Test frequency: Inductance measured@ 10kHz / 10mV

Test voltage between windings: 500Vrms

Operating temperature: -40°C to +125°C

Climatic category: IEC68-1 40/125/56

Part Number	I _{bc} Amps	L (µH) Typ. @ Rated Current	L _o (µH) ±15% No Load	DCR mOhms Typical	Energy Storage (µJ) ¹	Schematic ²			Coil Size O.D. x Ht. (a x b)	Housing Size Code		Mounting Style Terminals Ød		
						O	F	V		F	V	O	F	V
SD_-0.63-400	0.63	400	474	537	79	1	1	1	15 x 7	17	20	0.250	0.600	0.800
SD_-0.63-500		500	620	670	99	1	1	1	15 x 7	17	20	0.250	0.600	0.800
SD_-0.63-630		630	820	563	12	1	1	1	15 x 7	17	20	0.280	0.600	0.800
SD_-0.63-1000		1000	1157	650	198	1	1	1	19 x 9	22	25	0.300	0.600	0.800
SD_-0.63-2000		2000	2695	992	397	1	1	1	20 x 9	22	25	0.300	0.600	0.800
SD_-0.63-2500		2500	3080	730	496	1	1	1	26 x 12	29	30	0.400	0.600	0.800
SD_-0.63-4000		4000	5625	1000	794	1	1	1	26 x 12	29	30	0.400	0.600	0.800
SD_-0.63-6000		6000	7600	1150	1191	1	1	1	30 x 15	32	35	0.40	0.600	0.800
SD_-1.0-250	1.0	250	323	354	125	1	1	1	15 x 7	17	20	0.355	0.600	0.800
SD_-1.0-500		500	580	210	250	1	1	1	19 x 9	22	25	0.450	0.600	0.800
SD_-1.0-1000		1000	1250	290	500	1	1	1	26 x 12	29	30	0.500	0.600	0.800
SD_-1.0-2500		2500	4160	550	1250	1	1	1	26 x 12	29	30	0.500	0.600	0.800
SD_-1.0-4000		4000	5970	820	2000	1	1	1	30 x 15	32	35	0.450	0.600	0.800
SD_-1.0-6000		6000	9260	970	3000	1	2R	1	37 x 15	42	40	0.500	0.500	0.800
SD_-1.6-160	1.6	160	251	127	205	1	1	1	15 x 7	17	20	0.500	0.800	0.800
SD_-1.6-315		315	443	289	408	1	1	1	19 x 8	22	25	0.355	0.800	0.800
SD_-1.6-400		400	613	266	502	1	1	1	19 x 9	22	25	0.400	0.800	0.800
SD_-1.6-500		500	695	115	640	1	1	1	26 x 12	29	30	0.710	0.800	0.800
SD_-1.6-1000		1000	1290	195	1280	1	2R	1	30 x 15	32	35	0.630	0.630	0.800
SD_-1.6-2500		2500	3670	380	3200	1	1	1	37 x 15	42	40	0.630	0.800	0.800
SD_-1.6-4000		4000	5440	450	5140	1	1	--	44 x 18	49	--	0.630	0.800	--
SD_-2.0-63	2.0	63	81	87	126	1	1	1	14 x 6	17	20	0.400	0.800	0.800
SD_-2.0-100		100	115	161	200	1	1	1	19 x 8	22	25	0.355	0.800	0.800
SD_-2.0-315		315	422	168	650	1	1	1	25 x 9	29	30	0.800	0.800	0.800
SD_-2.0-630		630	885	120	1260	1	1	1	26 x 12	29	30	0.750	0.800	0.800
SD_-2.0-1000		1000	1387	145	2000	1	1	1	30 x 15	42	35	0.750	0.800	0.800
SD_-2.0-1600		1600	2420	200	3200	1	1	1	37 x 15	42	40	0.800	0.800	0.800
SD_-2.0-2500		2500	3240	313	5000	1	1	--	46 x 20	49	--	0.850	0.850	--
SD_-2.5-63	2.5	63	99	62	197	1	1	1	14 x 6	17	20	0.500	0.800	0.800
SD_-2.5-100		100	129	122	312	1	1	1	19 x 8	22	25	0.400	0.800	0.800
SD_-2.5-160		160	241	132	489	1	1	1	19 x 8	22	25	0.450	0.800	0.800
SD_-2.5-200		200	275	70	630	1	2R	1	26 x 12	29	30	0.750	0.750	0.800
SD_-2.5-400		400	790	120	1250	1	2R	1	26 x 12	29	30	0.710	0.710	0.800
SD_-2.5-1000		1000	1521	125	3125	1	2R	1	39 x 16	42	45	0.950	0.950	1.000
SD_-3.15-63	3.15	63	80	62	312	1	1	1	19 x 8	22	25	0.500	0.800	0.800
SD_-3.15-100		100	157	60	498	1	1	1	19 x 8	22	25	0.600	0.800	0.800
SD_-3.15-160		160	234	86	794	1	1	1	25 x 10	29	30	0.600	0.800	0.800
SD_-3.15-250		250	570	85	1240	1	2P	1	26 x 12	29	30	0.560	0.560	0.800
SD_-3.15-630		630	1122	110	3125	1	2R	1	37 x 15	42	40	0.900	0.900	0.900



SD Series • High Efficiency Storage Chokes

Electrical Specifications at 25°C

Part Number	I _{DC} Amps	L (μH) Typ. @ Rated Current	L ₀ (μH) ±15% No Load	DCR mOhms Typical	Energy Storage (μJ) ¹	Schematic ²			Coil Size O.D. x Ht. (a x b)	Housing Size Code		Mounting Style Terminals Ød		
						Mounting Style				F	V	O	F	V
						O	F	V			O	F	V	
SD__4.0-47	4.0	47	65	55	376	1	1	1	20 x 9	22	25	0.500	0.800	0.800
SD__4.0-100		100	144	68	800	1	1	1	25 x 10	29	30	0.600	0.800	0.800
SD__4.0-160		160	240	40	1280	1	1	1	26 x 12	29	30	0.900	1.000	0.900
SD__4.0-250		250	345	50	2000	1	1	1	30 x 15	42	45	0.950	1.000	1.000
SD__5.0-47	5.0	47	60	44	588	1	1	1	25 x 10	29	30	0.600	0.800	0.800
SD__5.0-63		63	91	43	797	1	1	1	25 x 10	29	30	0.670	0.800	0.800
SD__5.0-100		100	165	27	1250	2P	2P	2P	26 x 12	29	30	0.750	0.750	0.750
SD__5.0-250		250	357	40	3125	2R	1	1	39 x 16	42	45	1.180	1.180	1.180
SD__6.3-47	6.3	47	76	44	946	1	1	1	26 x 11	29	30	1.000	1.000	1.000
SD__6.3-63		63	120	17	1250	1	1	1	26 x 12	29A	30	1.180	1.180	1.180
SD__6.3-100		100	160	28	2010	1	1	1	29 x 13	32	35	0.670	0.800	0.800
SD__6.3-200		200	266	44	3969	2P	2P	2P	38 x 17	42	40	0.850	0.850	0.850
SD__8.0-47	8.0	47	63	43	1507	1	1	1	29 x 13	32	35	0.670	0.800	0.800
SD__8.0-63		63	95	12	2016	2P	2P	1	30 x 15	32	35	0.950	0.950	0.950

The Talema engineering staff can assist in the design of other inductance values and sizes including pre-designed cable lug models to 63 Amps.

1) The μJoule rating ($\frac{1}{2}LI^2$) is the ability of the inductor to store energy.

2) Schematic:

1 = one winding

2P = two windings, Parallel Connection

2R = two windings, Series Connection.

3) Inductance measured at 0.10 Vrms @ 10kHz without DC Current and 0.25 Vrms @ 10kHz with DC Current.

4) On larger units and units wound with fine wire, additional mechanical mounting is recommended. See next page for Mounting Styles.

Ordering Key

SD V - 0.63 - 500 μH

Inductance Value in μH

Current Rating (Amps)

Mounting Style - Specify the appropriate suffix

O = Open Mount

V = Vertical Encapsulated

F = Flat Encapsulated

Basic Series Designation

Sales & Marketing, Design and Manufacturing Facilities

<http://www.talema-nuvotem.com>

Eastern Europe & Czech Republic

NT MAGNETICS s.r.o.

Chebská 27

322 00 Plzeň

Tel: Int. + 420 377 - 338 351

Fax: Int. + 420 377 - 338 350

Email: talema@talema.cz

Web Site: www.ntmagnetics.cz

Germany

TALEMAELEKTRONIK GMBH

Sembdnerstr. 5, Postfach 2523

82110 Germering

Tel: Int. + 49 89 - 841 00 - 0

Fax: Int. + 49 89 - 841 00 25

Email: info@talema.de

Ireland

NUVOTEMTEO.

Croly

Co. Donegal

Tel: Int. + 353 74 - 954 8666

Fax: Int. + 353 74 - 954 8139

Email: info@nuvotem.com

India

TALEMA ELECTRONIC PVT. LTD.

Opposite the SIDCO Industrial Estate

Gins Towers

4/5S.H/1, Omalur Main Road

Salem - 636 004, Tamil Nadu

Tel: Int. + 91 427 - 244 1325

Fax: Int. + 91 427 - 243 0034

E-mail: talema@talemaindia.com

Web Site: www.talemaindia.com

Mounting Styles • SA and SD Series • High Efficiency Storage Chokes

Mounting Style "V"

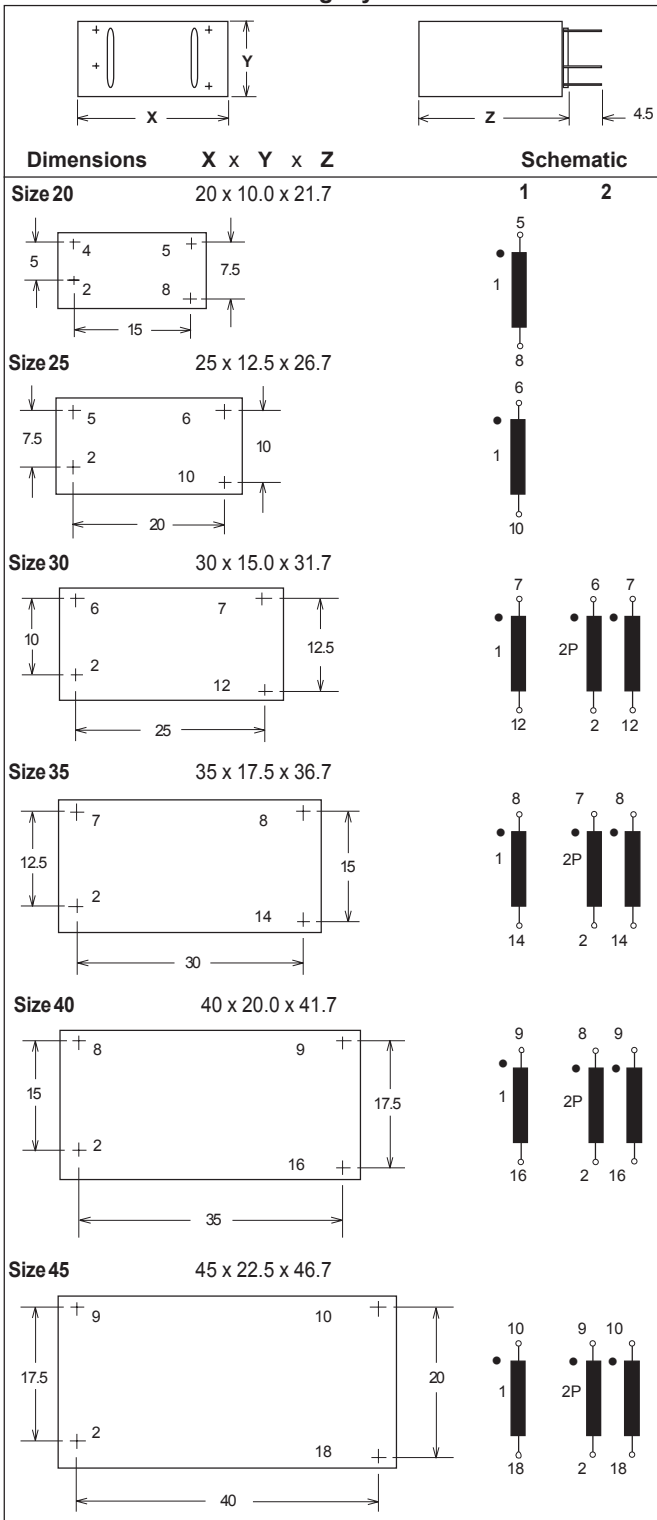

Mounting Style 'O' = Open Mount

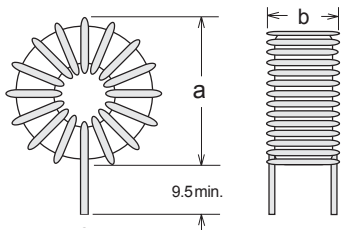

Mounting Style "F"

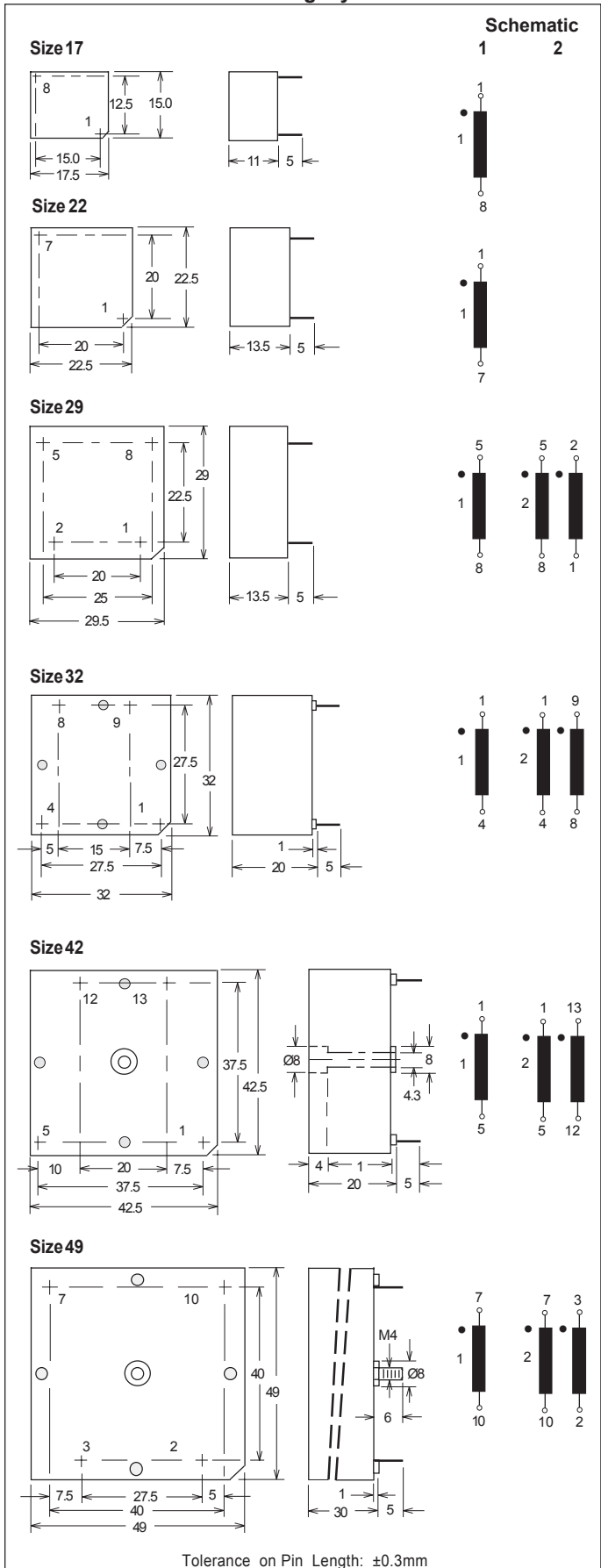



SL Series Toroidal Power Inductors

Features

- Operating frequency to 1MHz
- High energy storage with minimum saturation
- High stability from no load to full load
- Available in both SMD and TH versions
- Manufactured in ISO-9001:2000, TS-16949:2002 and ISO-14001:2004 certified Talema facility
- Meets lead free reflow level J-STD-020C
- Fully RoHS compliant

Electrical Specifications @ 25°C

Test voltage between windings: 500 Vrms

Operating temperature range: -40°C to +130°C

Climatic Category: IEC68-1 40/125/56

Test frequency: Inductance measured @ 10kHz / 10mV



Part Number	Rated Current (ID)	LN (µH) @ I rated ±20%	LO (µH) No Load ±20%	DCR (mOhms) Nominal	Energy Storage (µJ)	Package	
						"SMD"	"THT"
SL_-3.4-1.1	3.4	1.1	1.2	9.6	6	S1	T1
SL_-1.4-6.4	1.4	6.4	7.0	62.0	6	S1	T1
SL_-1.0-17.6	1.0	17.6	20.3	117.7	9	S1	T1
SL_-4.8-4.0	4.8	4.0	4.5	17.0	44	S2	T2
SL_-2.8-9.6	2.8	9.6	11.0	41.1	37	S2	T2
SL_-1.4-29.7	1.4	29.7	33.6	144.3	29	S2	T2
SL_-0.94-114	0.94	114	131.7	411.2	50	S2	T2
SL_-8.0-2.4	8.0	2.4	3.1	7.8	80	S3	T3
SL_-5.4-5.1	5.4	5.1	6.3	17.5	74	S3	T3
SL_-2.7-16.8	2.7	16.8	19.2	68.5	59	S3	T3
SL_-1.3-58.8	1.3	58.8	65.7	288.8	49	S3	T3
SL_-0.9-192	0.9	192	225.2	534.7	78	S3	T3
SL_-0.72-384	0.72	384	461	765.0	99	S3	T3
SL_-7.8-5.1	7.8	5.1	5.8	10.9	149	S4	T4
SL_-5.5-8.6	5.5	8.6	10.4	26.1	136	S4	T4
SL_-2.7-29	2.7	29	34.8	93.8	106	S4	T4
SL_-0.74-645	0.74	645	771.3	1267.2	177	S4	T4
SL_-14.3-0.84	14.3	0.84	1.2	2.3	83	SH3	--
SL_-11.5-1.32	11.5	1.32	1.7	3.2	87	SH3	--
SL_-13.9-1.7	13.9	1.7	2.2	3.3	162	SH4	--
SL_-11.4-2.5	11.4	2.5	3.0	4.9	162	SH4	--
SL_-7.2-9.7	7.2	9.7	11.8	15.1	241	S5	T5
SL_-5.1-16.1	5.1	16.1	19.1	27.3	209	S5	T5
SL_-2.6-50	2.6	50	56.9	117.2	169	S5	T5
SL_-0.71-1070	0.71	1070	1295	1616.1	270	S5	T5
SL_-12.4-3.6	12.4	3.6	4.5	5.9	269	SH5	--
SL_-10.4-4.9	10.4	4.9	6.3	7.1	254	SH5	--
SL_-15.4-5.4	15.4	5.4	7.0	5.5	617	SH6A	TH6A
SL_-10.9-9.6	10.9	9.6	12.2	11.3	558	SH6A	TH6A
Coupled Inductors							
SLC_-1.1-43.8	1.1	43.8	49.2	280.7	26	SC3	TC3
SLC_-2.7-23.5	2.7	23.5	26.0	81.0	80	SC4	--
SLC_-6.4-4.6	6.4	4.6	4.5	19.0	82	SC5	TC5
SLC_-23.8-0.56	23.8	0.56	0.6	1.2	150	SHC4	--
SLC_-21-1.0	21.0	1.0	1.8	2.1	243	SHC5	--
SLC_-22.4-2.0	22.4	2.0	2.8	3.1	527	SHC6	THC6

Note: The inductance values listed above are based on a 55°C temperature rise and 25°C ambient temperature.

Mounting Styles • SL Series Toroidal Power Inductors

Type S1 - S5

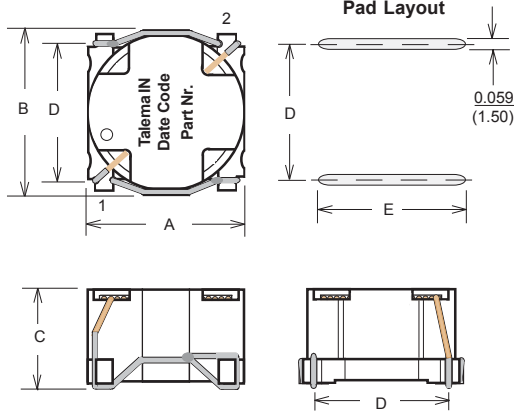

Schematic



Type T1 - T5

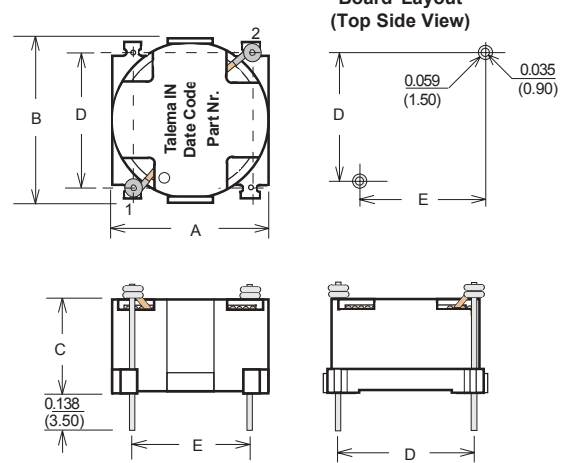

Type SH3 - SH6A

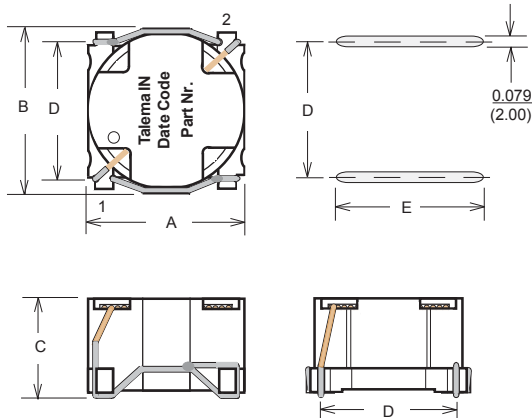

Schematic



Type TH6A

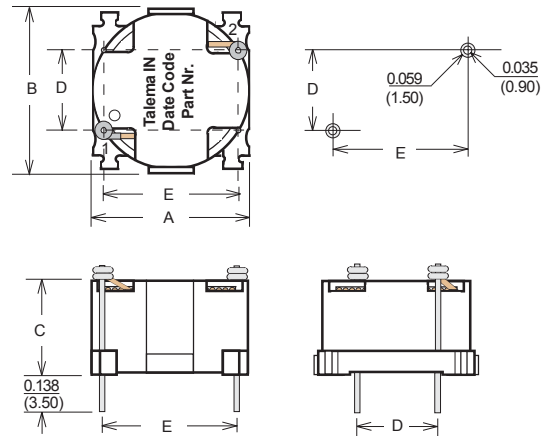

Coupling Transformers

Type SC3 - SC5

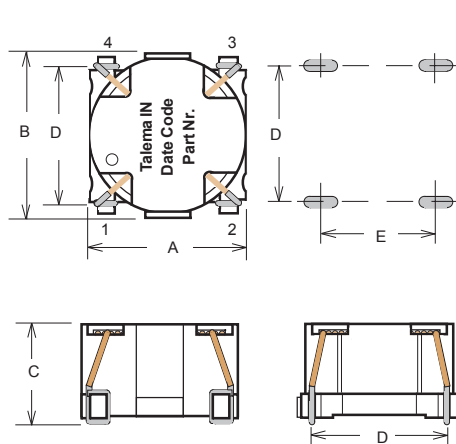

Schematic

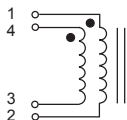

Type SC4

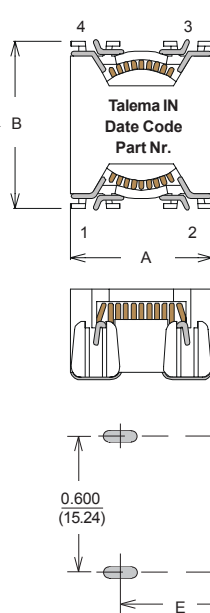

Type TC3 - TC5

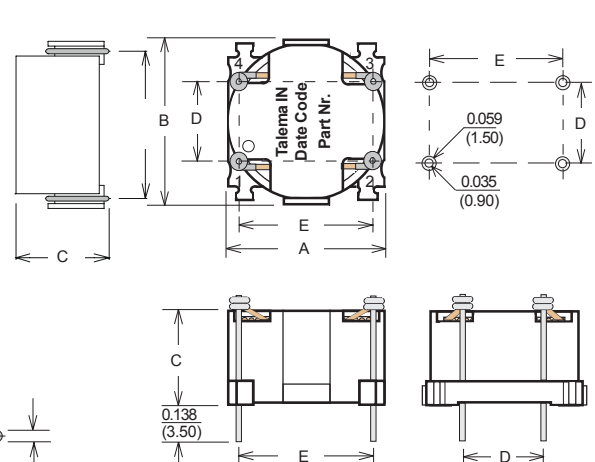



Mounting Styles • SL Series Toroidal Power Inductors

Coupling Transformers

Surface Mount Style

Type SHC4 - SHC6

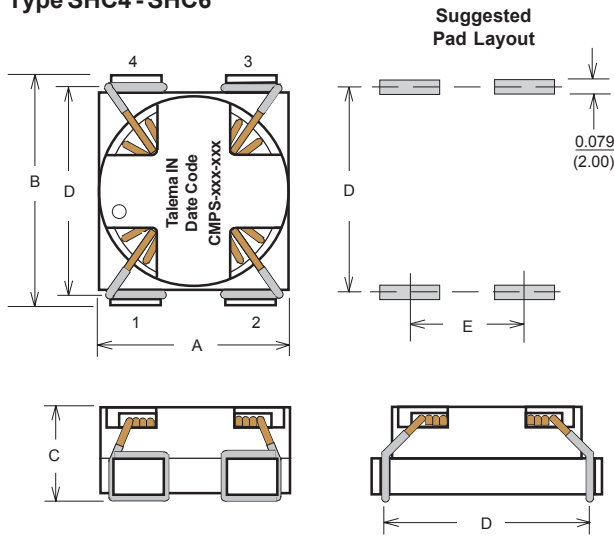

Through Hole Style

THC6

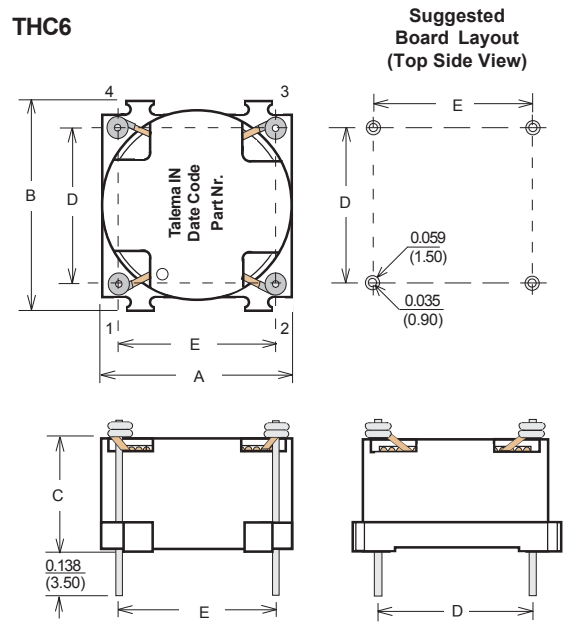

Note: When ordering, add "S" or "T" to the basic part number to denote preferred mounting style. Example: SLS-3.4-1.03 for SMD or SLT-3.4-1.03 for through hole mounting.

Mounting Style	Size Code	Dimensions - Inches ±0.010 (mm ±0.25)					Lead Ø
		A	B	C	D	E	
"S"	S1	0.339 (8.60)	0.339 (8.60)	0.220 (5.60)	0.268 (6.90)	0.354 (9.00)	
	S2	0.433 (11.00)	0.441 (11.20)	0.303 (7.70)	0.358 (9.10)	0.413 (10.50)	
	S3	0.551 (14.00)	0.559 (14.20)	0.343 (8.70)	0.461 (11.70)	0.520 (13.20)	
	S4	0.591 (15.00)	0.614 (15.60)	0.390 (9.90)	0.508 (12.90)	0.551 (14.00)	
	S5	0.669 (17.00)	0.701 (17.80)	0.441 (11.20)	0.591 (15.00)	0.630 (16.00)	
"SH"	SH3	0.620 (15.75)	0.605 (15.37)	0.370 (9.40)	0.500 (12.70)	0.500 (12.70)	
	SH4	0.670 (17.02)	0.670 (17.02)	0.390 (9.90)	0.560 (14.22)	0.490 (12.45)	
	SH5	0.740 (18.80)	0.740 (18.80)	0.390 (9.90)	0.630 (16.00)	0.640 (16.26)	
	SH6A	0.925 (23.50)	0.957 (24.30)	0.445 (11.30)	0.843 (21.40)	0.728 (18.50)	
"SC"	SC3	0.551 (14.00)	0.630 (16.00)	0.343 (8.70)	0.530 (13.46)	0.348 (8.84)	
	SC4	0.590 (14.99)	0.715 (18.16)	0.390 (9.91)	0.600 (15.24)	0.370 (9.40)	
	SC5	0.662 (16.82)	0.760 (19.31)	0.413 (10.50)	0.660 (16.76)	0.445 (11.30)	
"SHC"	SHC4	0.715 (18.16)	0.865 (21.97)	0.390 (9.91)	0.760 (19.30)	0.360 (9.14)	
	SHC5	0.800 (20.32)	0.910 (23.11)	0.390 (9.91)	0.800 (20.32)	0.440 (11.18)	
	SHC6	1.000 (25.40)	1.104 (28.05)	0.409 (10.40)	1.010 (25.65)	0.620 (15.75)	
"T"	T1	0.339 (8.60)	0.339 (8.60)	0.201 (5.10)	0.250 (6.35)	0.250 (6.35)	0.020 (0.50)
	T2	0.433 (11.00)	0.441 (11.20)	0.280 (7.10)	0.300 (7.62)	0.300 (7.62)	0.020 (0.50)
	T3	0.551 (14.00)	0.559 (14.20)	0.311 (7.90)	0.375 (9.52)	0.375 (9.52)	0.020 (0.50)
	T4	0.591 (15.00)	0.614 (15.60)	0.358 (9.10)	0.300 (7.62)	0.500 (12.70)	0.022 (0.55)
	T5	0.669 (17.00)	0.701 (17.80)	0.409 (10.40)	0.600 (15.24)	0.500 (12.70)	.026 (0.65)
"TH"							
	TH6A	0.925 (23.50)	0.957 (24.30)	0.386 (9.80)	0.650 (16.51)	0.800 (20.32)	0.031 (0.80)
"TC"	TC3	0.551 (14.00)	0.630 (16.00)	0.327 (8.30)	0.500 (12.70)	0.400 (10.16)	0.024 (0.60)
	TC5	0.662 (16.82)	0.760 (19.31)	0.362 (9.20)	0.500 (12.70)	0.500 (12.70)	0.024 (0.60)
"THC"							
	THC6	1.000 (25.40)	1.104 (28.05)	0.357 (9.08)	1.000 (25.40)	0.600 (15.24)	0.028 (0.70)



SH50 Series • Inductors for National's 50kHz Simple Switcher™

Compatible with National Semiconductor's Simple Switcher™ Part Number's LM2574, LM2475 and LM2576

Features

- High energy storage with minimum saturation
- High stability from no load to full load
- Available in both SMD and THT versions
- Manufactured in ISO-9001:2000, TS-16949:2002 and ISO-14001:2004 certified Talema facility
- Meets lead free reflow level J-STD-020C
- Fully RoHS compliant

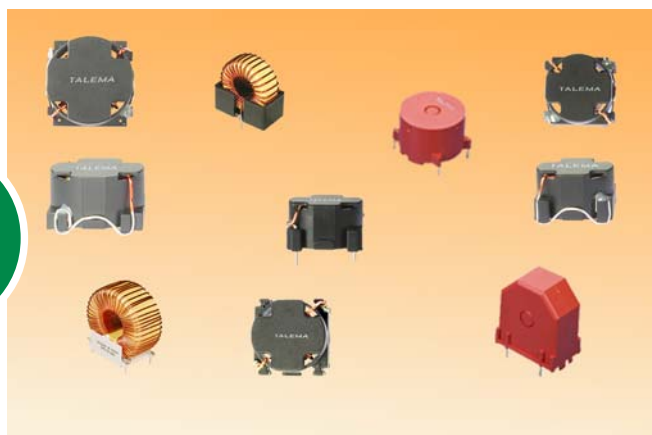

Electrical Specifications @ 25°C

Test voltage between windings: 500 Vrms

Operating temperature range: -40°C to +125°C

Climatic Category: IEC68-1 40/125/56

Test frequency: Inductance measured @ 10kHz / 10mV

Part Number	Rated Current (I _{DC})	L _N (μH) Typical *	L _O (μH) ±20% No DC Load	ET _{OP} (V-μSec) Max.	DCR (Ohms) Max.	Package					
						"C"	"S"	"T"	"B"	"F"	"V"
SH50_-3.0-47	3.0	47	38	90	0.05	2	5	*			
SH50C-5.0-36	5.0	36	55	90	0.02	4					
SH50C-3.0-100	3.0	100	91	90	0.04	4					
SH50_-2.0-150	2.0	150	130	90	0.10	4	6	6			
SH50_-1.4-220	1.4	220	230	90	0.38		5	*		2	2
SH50_-1.4-176	1.4	220	176	90	0.14	3	6A	6A			
SH50_-0.9-330	0.9	330	302	90	0.74		5	*		2	2
SH50_-0.9-267	0.9	330	267	90	0.18	3	6A	6A			
SH50C-0.64-470	0.64	470	426	90	0.16	4					
SH50_-0.85-680	0.85	680	657	90	1.25		5	*		2	2
SH50C-3.0-150	3.0	150	136	200	0.10	4					
SH50C-3.0-220	3.0	220	167	200	0.07	5					
SH50C-3.0-330	3.0	330	292	200	0.15	5					
SH50C-2.0-470	2.0	470	369	200	0.17	5					
SH50C-1.3-680	1.3	680	562	200	0.20	5					
SH50C-0.95-1000	0.95	1000	762	200	0.24	5					
SH50B-0.62-1500	0.62	1500	1150	200	1.00				8		
SH50B-0.42-2200	0.42	2200	1730	200	1.80				8		

* The previous SW "T" (size 5 - plate version) has been discontinued and replaced with a pin equivalent "Flat Mount" - Package SH50F, size 2. Dimensions on the following Mounting Styles page.

Notes:

- 1) Inductance will be typical for the I_{DC} and ET_{OP} values listed above.
- 2) No load Inductance measured at B_{OP} maximum of 10 gauss (10mV @ 20kHz).
- 3) Simple Switcher™ is a trademark of National Semiconductor Corporation.

Ordering Key

SH50 C - 3.0 - 47

- Inductance Value in μH
- Current Rating (Amps)
- Mounting Style - Specify the appropriate suffix
 - C = Clip Mount
 - S = Surface Mount (S5 or S6)
 - T = Low Profile TH Mount
 - B = Base Mount
 - F = Flat Encapsulated
 - V = Vertical Encapsulated
- Basic Series Designation

Mounting Styles • SH50 Series - Low Cost Toroidal Inductors

Type SH50B - Vertical Mount

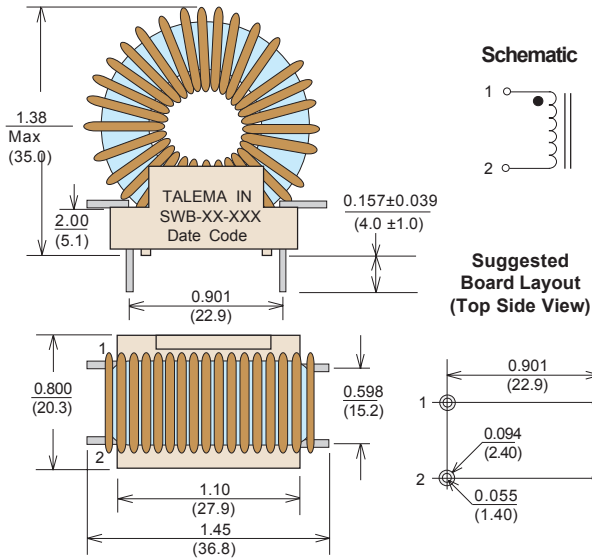

Type SH50V - Vertical Mount - Size 2

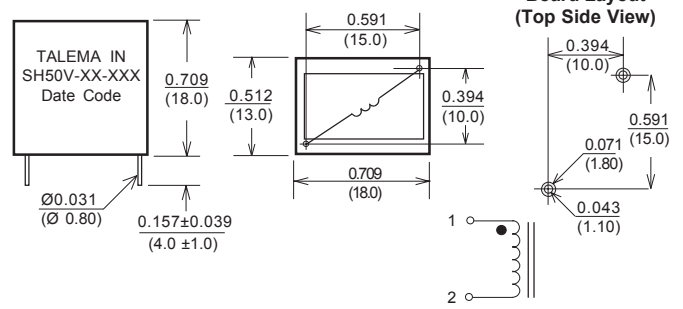

Type SH50F - Flat Mount - Size 2

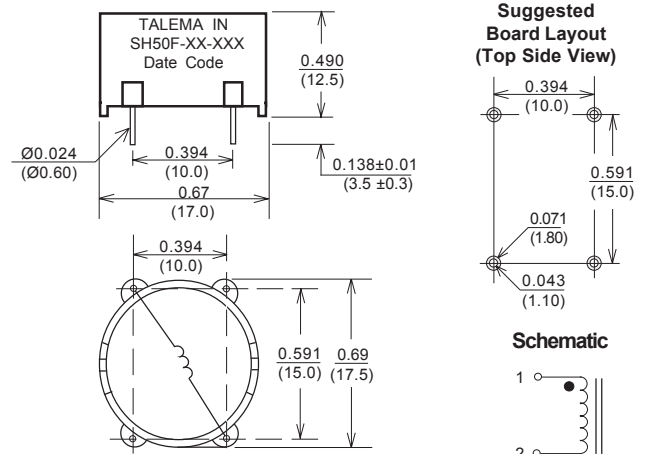

Type SH50T - Through Hole Mount

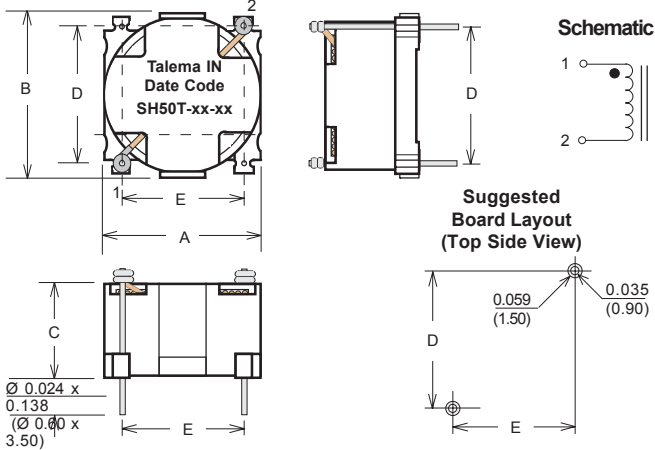

Type SH50C - Clip Mount

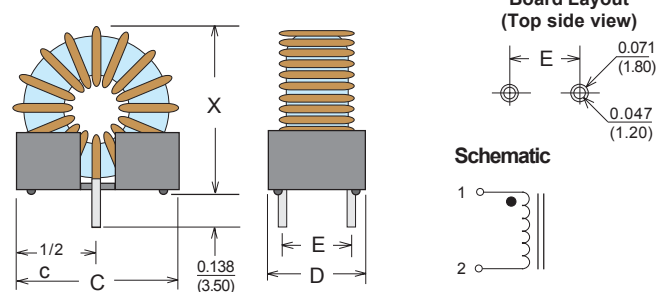

Type SH50S - Surface Mount

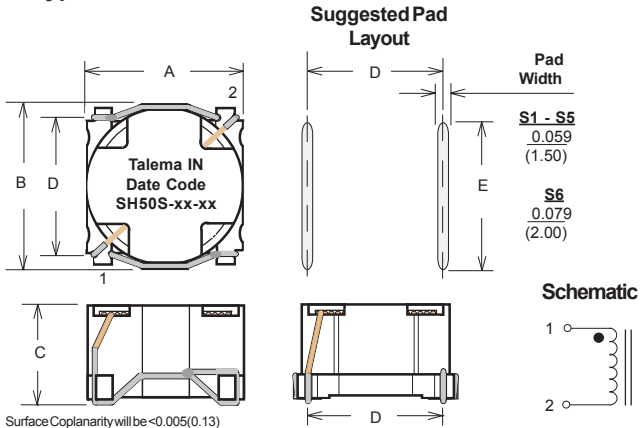

Mounting Style	Size Code	Dimensions - Inches ± 0.010 (mm ± 0.25)			
		C	D	E	X = Coil O.D. +
"C" Vertical Clip Mount	C2	0.650 (16.5)	0.449 (11.4)	0.299 (7.60)	0.110 (2.80)
	C3	0.827 (21.0)	0.449 (11.4)	0.299 (7.60)	0.110 (2.80)
	C4	0.949 (24.1)	0.598 (15.2)	0.449 (11.4)	0.110 (2.80)
	C5	1.252 (31.8)	0.701 (17.8)	0.500 (12.7)	0.130 (3.30)

Mounting Style	Size Code	Dimensions - Inches ± 0.010 (mm ± 0.25)				
		A	B	C	D	E
"S" SMD	S5	0.669 (17.0)	0.701 (17.8)	0.441 (11.2)	0.591 (15.0)	0.630 (16.0)
	S6	0.925 (23.5)	0.957 (24.3)	0.555 (14.1)	0.843 (21.4)	0.748 (19.0)
	SH6A	0.925 (23.5)	0.957 (24.3)	0.402 (10.2)	0.843 (21.4)	0.748 (19.0)
"T" THT	Size Code	Dimensions - Inches ± 0.010 (mm ± 0.25)				
		A	B	C	D	E
		T6	0.925 (23.5)	0.957 (24.3)	0.531 (13.5)	0.650 (16.51)
TH6A	0.925 (23.5)	0.957 (24.3)	0.386 (9.8)	0.650 (16.51)	0.800 (20.32)	



SH150 Series • Inductors for National's 150kHz Simple Switcher™

SH150 Series low cost toroidal inductors, designed for use with National Semiconductor's 150kHz Simple Switcher™ Part Numbers LM259X-L1 through LM259X-L44 and LM258X-L

Features

- High energy storage with minimum saturation
- High stability from no load to full load
- Available in both SMD and TH versions
- Manufactured in ISO-9001:2000, TS-16949:2002 and ISO-14001:2004 certified Talema facility
- Meets lead free reflow level J-STD-020C
- Fully RoHS compliant



Electrical Specifications @ 25°C

Test voltage between windings: 500 Vrms

Operating temperature range: -40°C to +125°C

Climatic Category: IEC68-1 40/125/56

Test frequency: Inductance measured @ 10kHz / 10mV

Part Number	National Part Number	Rated Current (i _{DC})	L _N (μH) ±20%	ET _{OP} (V·μSec) Max.	DCR (Ohms)	Energy Storage (μJ)	Package	
							"S"	"C" & "T"
SH150_-0.13-259	LM-259X-L1	0.13	259	23.1	3.40	2	S1	T1
SH150_-0.16-178	LM-259X-L2	0.16	178	16.5	2.80	2		
SH150_-0.20-118	LM-259X-L3	0.20	118	13.2	1.80	2		
SH150_-0.25-79	LM-259X-L4	0.25	79	9.9	1.50	2		
SH150_-0.30-55	LM-259X-L5	0.30	55	6.6	1.00	2		
SH150_-0.34-39	LM-259X-L6	0.34	39	6.6	0.80	2		
SH150_-0.45-26	LM-259X-L7	0.45	26	6.6	0.62	3		
SH150_-0.20-374	LM-259X-L8	0.20	374	75.9	2.70	7	S2	T2
SH150_-0.25-256	LM-259X-L9	0.25	256	33.0	2.20	8		
SH150_-0.30-176	LM-259X-L10	0.30	176	26.4	1.40	8		
SH150_-0.38-118	LM-259X-L11	0.38	118	19.8	1.20	9		
SH150_-0.46-78	LM-259X-L12	0.46	78	16.5	0.80	8		
SH150_-0.56-55	LM-259X-L13	0.56	55	13.2	0.50	9		
SH150_-0.68-39	LM-259X-L14	0.68	39	9.9	0.30	9		
SH150_-0.84-26	LM-259X-L15	0.84	26	6.6	0.20	9	S3	T3
SH150_-1.02-17	LM-259X-L16	1.02	17	6.6	0.10	9		
SH150_-0.36-375	LM-259X-L17	0.36	375	75.9	1.30	24		
SH150_-0.44-252	LM-259X-L18	0.44	252	49.5	0.90	24		
SH150_-0.54-173	LM-259X-L19	0.54	173	36.3	0.60	25		
SH150_-0.67-115	LM-259X-L20	0.67	115	29.7	0.40	26		
SH150_-0.82-78	LM-259X-L21	0.82	78	23.1	0.30	26		
SH150_-1.0-54	LM-259X-L22	1.00	54	16.5	0.20	27	S4	T4
SH150_-1.2-38	LM-259X-L23	1.20	38	13.2	0.10	27		
SH150_-1.48-26	LM-259X-L24	1.48	26	9.9	0.10	28		
SH150_-1.81-18	LM-259X-L25	1.81	18	9.9	0.06	29		
SH150_-0.68-377	LM-259X-L26	0.68	377	75.9	1.00	87		
SH150_-0.83-248	LM-259X-L27	0.83	248	72.6	0.60	85		
SH150_-1.02-168	LM-259X-L28	1.02	168	56.1	0.40	87		
SH150_-1.26-112	LM-259X-L29	1.26	112	42.9	0.30	89	SH6A	C1 - T4
SH150_-1.54-77	LM-259X-L30	1.54	77	33.0	0.20	91		
SH150_-1.87-53	LM-259X-L31	1.87	53	26.4	0.13	93		
SH150_-2.24-37	LM-259X-L32	2.24	37	19.8	0.10	93		
SH150_-2.74-24	LM-259X-L33	2.74	24	16.5	0.07	90	SH6A	C3 - TH6A
SH150_-3.00-17	LM-259X-L34	3.00	17	13.2	0.05	77		
SH150_-1.5-250	LM-259X-L35	1.50	250	72.6	0.23	281		
SH150_-1.81-168	LM-259X-L36	1.81	168	75.9	0.18	275		

THE TALEMA GROUP • Magnetic Components for Universal Applications

SH150 Series • Toroidal Inductors for National's 150kHz Simple Switcher™

Electrical Specifications at 25°C

Part Number	National Part Number	Rated Current (I _{DC})	L _N (μH) ±20%	ET _{OP} (V-μSec) Max.	DCR (Ohms)	Energy Storage (μJ)	Package	
							"S"	"C", "T" & "F"
SH150_-2.22-114	LM-259X-L37	2.22	114	62.7	0.10	281	SH6A	C3 - TH6A
SH150_-2.70-77	LM-259X-L38	2.70	77	52.8	0.09	281		
SH150_-3.00-53	LM-259X-L39	3.00	53	42.9	0.08	239		
SH150_-3.00-38	LM-259X-L40	3.00	38	29.7	0.05	171	S5	F2 - C2
SH150_-2.50-167	LM-259X-L42	2.50	167	75.9	0.14	522	SHC7	C4
SH150_-3.00-110	LM-259X-L43	3.00	110	75.9	0.09	495	SH6A	C3 - TH6A
SH150_-3.00-77	LM-259X-L44	3.00	77	59.4	0.08	347		
SH150_-4.50-19	LM-258X-L	4.50	19	32.0*	0.02	192		

*Note: ET_{OP} for P/N SH150_-4.50-19 is based on a frequency of 100kHz. All other items are rated at 150kHz. Simple Switcher™ is a trademark of National Semiconductor Corporation.

Dimensions

Type SHS - Surface Mount

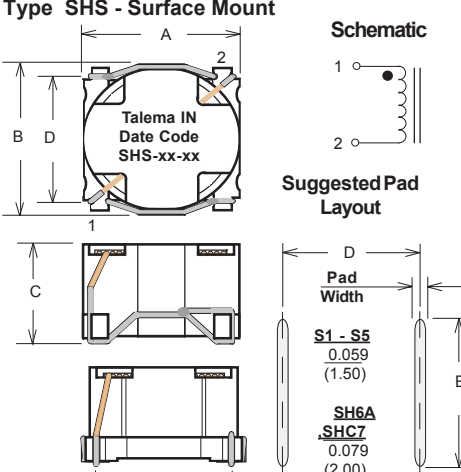

Schematic

Suggested Pad Layout

Pad Width

S1 - S5
0.059 (1.50)

SH6A
SHC7
0.079 (2.00)

Surface Coplanarity will be <0.005(0.13)

Type SHT - Through Hole Mount

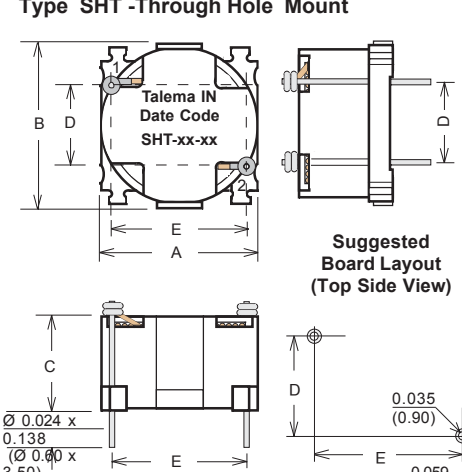

Schematic

Suggested Board Layout (Top Side View)

0.035 (0.90)

0.059 (1.50)

Type SHC - Clip Mount

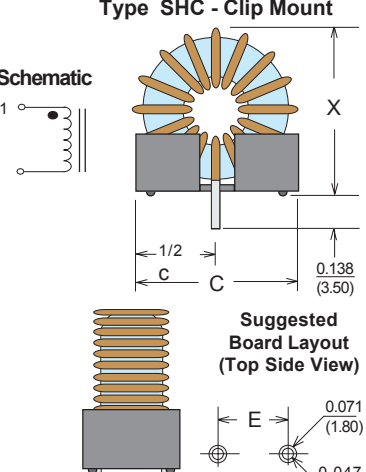

Schematic

Suggested Board Layout (Top Side View)

0.138 (3.50)

0.071 (1.80)

0.047 (1.20)

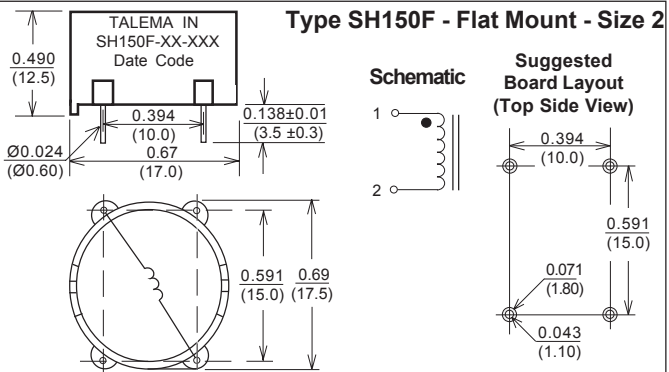
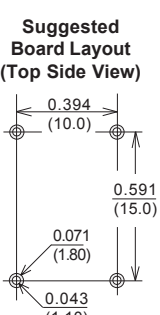
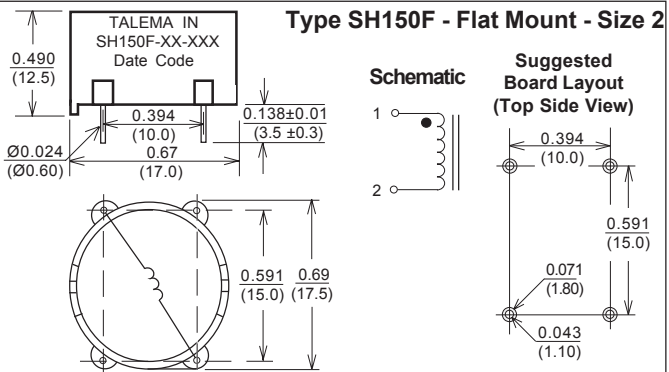
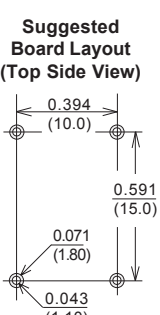
Mounting Style	Size Code	Dimensions - Inches ±0.010 (mm ±0.25)					Schematic	Suggested Board Layout (Top Side View)
		A	B	C	D	E		
"S" SMD	S1	0.339 (8.6)	0.339 (8.6)	0.205 (5.2)	0.268 (6.9)	0.378 (9.6)		
	S2	0.433 (11.0)	0.441 (11.2)	0.291 (7.4)	0.358 (9.1)	0.433 (11.0)		
	S3	0.551 (14.0)	0.559 (14.2)	0.327 (8.3)	0.461 (11.7)	0.520 (13.2)		
	S4	0.591 (15.0)	0.614 (15.6)	0.376 (9.6)	0.508 (12.9)	0.551 (14.0)		
	S5	0.669 (17.0)	0.701 (17.8)	0.433 (11.0)	0.591 (15.0)	0.630 (16.0)		
	SH6A	0.925 (23.5)	0.957 (24.3)	0.402 (10.2)	0.843 (21.4)	0.748 (19.0)		
	SHC7	1.000 (25.4)	1.213 (30.8)	0.465 (11.8)	1.100 (27.94)	0.915 (23.24)		
"T" TH	T1	0.339 (8.6)	0.339 (8.6)	0.201 (5.1)	0.250 (6.35)	0.250 (6.35)		
	T2	0.433 (11.0)	0.441 (11.2)	0.280 (7.1)	0.300 (7.62)	0.300 (7.62)		
	T3	0.551 (14.0)	0.559 (14.2)	0.311 (7.9)	0.375 (9.52)	0.375 (9.52)		
	T4	0.591 (15.0)	0.614 (15.6)	0.358 (9.1)	0.300 (7.62)	0.500 (12.7)		
	TH6A	0.925 (23.5)	0.957 (24.3)	0.386 (9.8)	0.650 (16.51)	0.800 (20.32)		
	"C" Vertical Clip Mount	C1	0.580 (14.73)	0.340 (8.64)	0.220 (5.58)	X = Coil O.D. + 0.110 (2.80)		
C2		0.650 (16.5)	0.449 (11.4)	0.299 (7.60)	0.110 (2.80)			
C3		0.827 (21.0)	0.449 (11.4)	0.299 (7.60)	0.110 (2.80)			
C4		0.949 (24.1)	0.598 (15.2)	0.449 (11.4)	0.110 (2.80)			
C5		1.252 (31.8)	0.701 (17.8)	0.500 (12.7)	0.130 (3.30)			



SH260 Series • Inductors for National's 260kHz Simple Switcher™

Compatible with National Semiconductor's Simple Switcher™
Part Numbers LM267X-L41 and LM267X-L45 through
LM267X-L50

Features

- High energy storage with minimum saturation
- High stability from no load to full load
- Available in both SMD and THT versions
- Manufactured in ISO-9001:2000, TS-16949:2002 and ISO-14001:2004 certified Talema facility
- Meets lead free reflow level J-STD-020C
- Fully RoHS compliant



Electrical Specifications @ 25°C

Test voltage between windings: 500 Vrms

Operating temperature range: -40°C to +125°C

Climatic Category: IEC68-1 40/125/56

Test frequency: Inductance measured @ 10kHz / 10mV

Part Number	National Part Number	Rated Current (I _{DC})	Inductance (μH) ±20%	ET _{OP} (V-μSec) Max. @ 260kHz	DCR Nominal (mOhm)	Package Size	
						Package Code	Lead Dia. (mm)
SH260C-4.9-23	LM267X-L41	4.9	22.8	23.3	36	C3	0.80
SH260C-4.3-10	LM267X-L45	4.3	10.2	10.0	26	C1	0.75
SH260C-5.0-15	LM267X-L46	5.0	14.8	17.0	23	C2	0.80
SH260C-5.0-10	LM267X-L47	5.0	10	13.0	25	C2	0.75
SH260C-5.0-50	LM267X-L48	5.0	50	40.0	50	C4	0.90
SH260C-5.0-33	LM267X-L49	5.0	33	36.0	47	C4	0.80
SH260C-5.0-23	LM267X-L50	5.0	23	24.0	26	C3	0.80
SH260S-4.9-23	LM267X-L41	4.9	22.8	23.3	36	SH6A	
SH260S-4.3-10	LM267X-L45	4.3	10	10.0	26	S4	
SH260S-5.0-15	LM267X-L46	5.0	15	17.0	27	S5	
SH260S-5.0-10	LM267X-L47	5.0	11	13.0	25	S5	
SH260S-5.0-50	LM267X-L48	5.0	52*	40.0	25	SHC7	
SH260S-5.0-33	LM267X-L49	5.0	36*	36.0	19	SHC7	
SH260S-5.0-23	LM267X-L50	5.0	24.7*	24.0	13	SHC7	
SH260T-4.9-23	LM267X-L41	4.9	22.8	23.3	36	TH6A	
SH260T-4.3-10	LM267X-L45	4.3	10	10.0	26	T4	
SH260T-5.0-15	LM267X-L46	5.0	15	17.0	27	F2	
SH260T-5.0-10	LM267X-L47	5.0	11	13.0	25	F2	

* Note: Series connection with pins 2 - 4 connected

Type SW260C - Clip Mount

Part Number	Size Code	Dimensions - Inches ±0.01 (mm ±0.25)				
		C	D	E	Coil OD	X = Coil OD +
SH260C-4.3-10	C1	0.580 (14.73)	0.340 (8.64)	0.220 (5.58)	0.605 (15.40)	0.110 (2.80)
SH260C-5.0-15	C2	0.650 (16.50)	0.449 (11.40)	0.299 (7.60)	0.640 (16.26)	0.110 (2.80)
SH260-5.0-10	C2	0.650 (16.50)	0.449 (11.40)	0.299 (7.60)	0.590 (15.00)	0.110 (2.80)
SH260C-4.9-23	C3	0.827 (21.00)	0.449 (11.40)	0.299 (7.60)	0.840 (21.34)	0.110 (2.80)
SH260C-5.0-23						
SH260C-5.0-50	C4	0.949 (24.10)	0.598 (15.20)	0.449 (11.40)	1.240 (31.50)	0.110 (2.80)
SH260C-5.0-33						

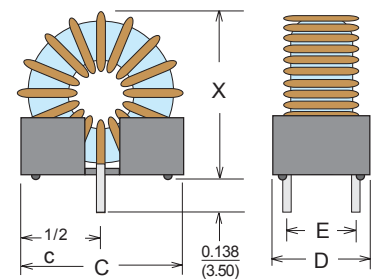

Suggested Board Layout (Top Side View)

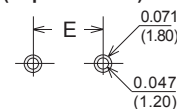

Schematic

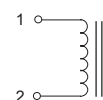

Germany: Int.+4989-841 00-0 • Ireland: Int.+35 374 - 954 8666 • Czech Rep: Int.+420 377 - 338 351 • India: Int.+91 427 - 244 1325
<http://www.talema-nuvotem.com>

Mounting Styles • SH260 Series • Low Cost Toroidal Inductors

S4, S5, SH6A

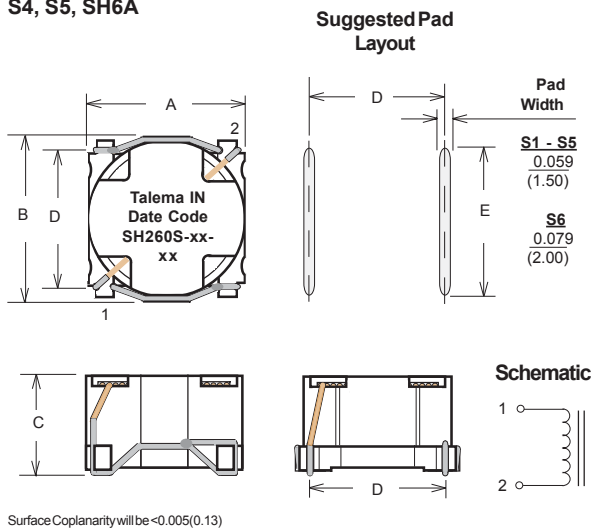

SHC7

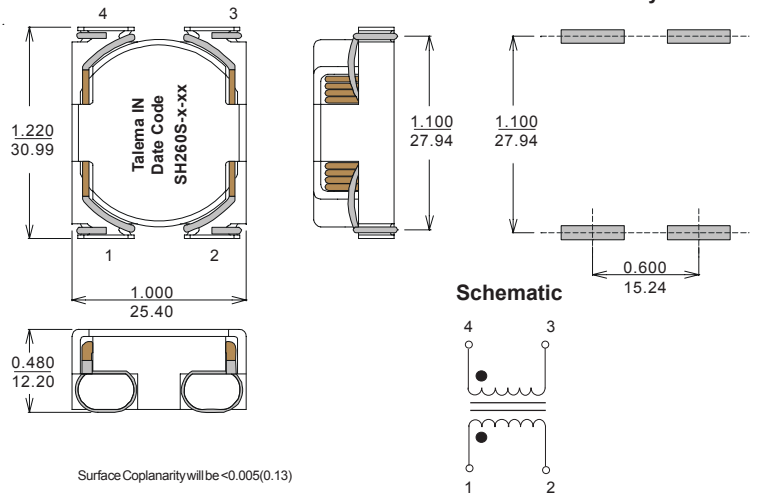

T4 & TH6A

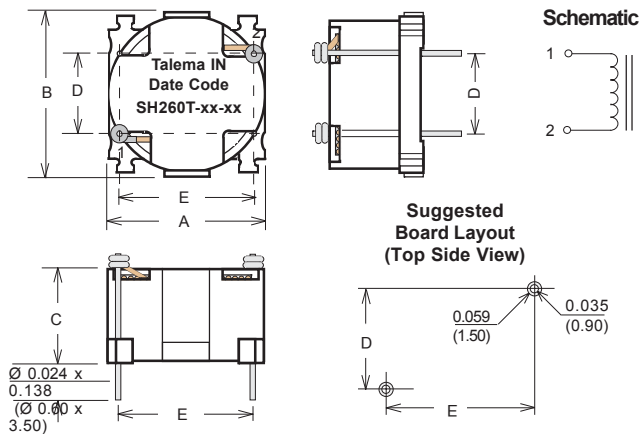

Mounting Style	Size Code	Dimensions - Inches ± 0.010 (mm ± 0.25)				
		A	B	C	D	E
"S" SMD	S4	0.591 (15.0)	0.614 (15.6)	0.394 (10.0)	0.508 (12.9)	0.551 (14.0)
	S5	0.669 (17.0)	0.701 (17.8)	0.441 (11.2)	0.591 (15.0)	0.630 (16.0)
	SH6A	0.925 (23.5)	0.957 (24.3)	0.417 (10.6)	0.827 (21.0)	0.748 (19.0)
"T" THT	T4	0.591 (15.0)	0.614 (15.6)	0.358 (9.10)	0.300 (7.62)	0.500 (12.70)
	TH6A	0.925 (23.5)	0.957 (24.3)	0.386 (9.80)	0.650 (16.51)	0.800 (20.32)

Type SH260F - Flat Mount - Size F2

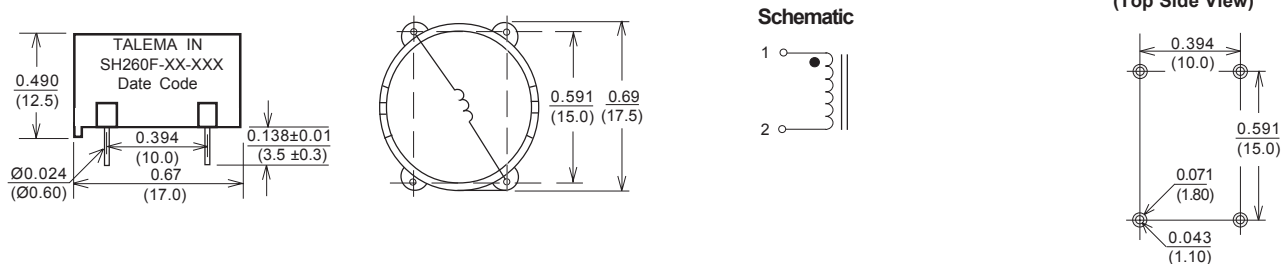

Sales & Marketing, Design and Manufacturing Facilities

<http://www.talema-nuvotem.com>

Eastern Europe & Czech Republic

NT MAGNETICS s.r.o.
Chebská 27
322 00 Plzeň
Tel: Int. + 420 377 - 338 351
Fax: Int. + 420 377 - 338 350
Email: talema@talema.cz
Web Site: www.ntmagnetics.cz

Germany

TALEMA ELEKTRONIK GMBH
Sembdnerstr. 5, Postfach 2523
82110 Germering
Tel: Int. + 49 89 - 841 00 - 0
Fax: Int. + 49 89 - 841 00 25
Email: info@talema.de

Ireland

NUVOTEM TEO.
Crolló
Co. Donegal
Tel: Int. + 353 74 - 954 8666
Fax: Int. + 353 74 - 954 8139
Email: info@nuvotem.com

India

TALEMA ELECTRONIC PVT. LTD.
Opposite the SIDCO Industrial Estate
Gins Towers
4/5S.H/1, Omalur Main Road
Salem - 636 004, Tamil Nadu
Tel: Int. + 91 427 - 244 1325
Fax: Int. + 91 427 - 243 0034
E-mail: talema@talemaindia.com
Web Site: www.talemaindia.com



SC Series • Low Profile Power Inductors • SMD & THT

Features

- Operating frequency to 1 MHz
- High energy storage with minimum saturation
- High stability from no load to full load
- Pick and place compatible
- Designed as 1:1 Coupled Inductor (Series or Parallel) or as 1:1 Isolation Transformer
- Manufactured in an ISO-9001:2000, TS-16949:2002 and ISO-14001:2004 certified Talema facility
- Meets lead free reflow level J-STD-020C
- Fully RoHS compliant

Electrical Specifications at 25°C

Test frequency: Inductance measured @ 10kHz/10mV

Test Voltage between windings: 500Vrms

Operating Temperature: -40°C to +130°C

Climatic category: IEC68-1 40/130/56



Part Number	Parallel Connected					Series Connected					Energy Storage (μJ) ²
	Rated Current (I_{DC})	L_N (μH) @ I rated	L_O (μH) $\pm 20\%$ No Load	DCR mOhm	ET (V- μsec)	Rated Current (I_{DC})	L_N (μH) @ I rated	L_O (μH) $\pm 20\%$ No Load	DCR mOhm	ET (V- μsec)	
SCS-14.4-1.5	14.40	1.5	2.2	4.4	4.8	7.20	6.0	8.8	17.6	9.6	159.0
SCS-11.2-2.4	11.20	2.4	3.5	6.5	6.0	5.60	9.6	14.0	28.6	12.0	152.8
SCS-8.2-4.2	8.20	4.2	5.9	10.5	7.9	4.10	16.8	23.6	42.0	15.8	142.6
SCS-6.8-5.8	6.80	5.8	7.9	15.0	9.1	3.40	23.2	31.6	60.0	18.2	133.8
SCS-5.7-7.6	5.70	7.6	10.1	21.0	10.3	2.85	30.4	40.4	84.0	20.6	124.2
SCS-5.4-12.1	5.40	12.1	18.5	23.3	13.9	2.70	48.4	74.0	93.2	27.8	176.6
SCS-4.4-18.0	4.40	18.0	27.4	38.2	16.5	2.20	72.0	109.6	152.8	33.0	174.3
SCS-3.54-27.0	3.54	27.0	40.5	53.2	20.5	1.77	108.0	162.0	212.8	41.0	169.1
SCS-3.0-34.8	3.00	34.8	50.5	74.0	22.5	1.50	139.2	202.0	296.0	45.0	156.5

Talema's engineering staff can assist in the design of other inductance values and sizes.

Note: When ordering, add "S" or "T" to the basic part number to denote preferred mounting style. Example: SCS-14.4-1.5 for SMD or SCT-14.4-1.5 for THT mounting.

Dimensions

Type SCS

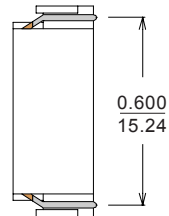
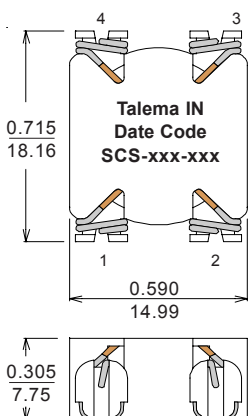

Suggested Pad Layout

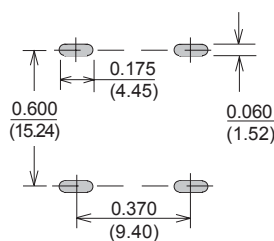

Schematic

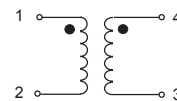

Dimensions: Inches (Millimeters)

Tolerance: ± 0.010 (0.25) unless specified otherwise

Tape & Reel Packaging and Dimensions

Dimensions for Carrier Tape (Unit : mm)

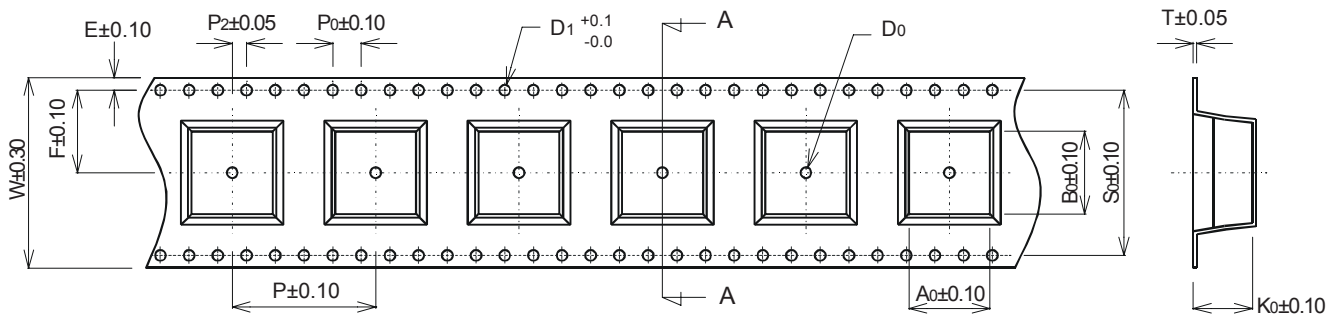

Section A-A

Type	Package Size	Dimensions in mm													Reel Size	Quantity (Pcs/Reel)	Quantity (Reel/Cased)
		W	F	E	P ₂	P ₀	D ₀	D ₁	P	A ₀	B ₀	S ₀	T	K ₀			
TVH	SC3	32.00	14.20	1.75	2.00	4.00	Ø1.5	Ø2.00	24.00	14.30	16.30	28.40	0.50	9.10	330x32	300	5/1500
	SC5	32.00	14.20	1.75	2.00	4.00	Ø1.5	Ø2.00	24.00	17.12	19.61	28.40	0.50	10.13	330x32	220	5/1100
CMP & CMPS	SC5	32.00	14.20	1.75	2.00	4.00	Ø1.5	Ø2.00	24.00	17.12	19.61	28.40	0.50	10.13	330x32	220	5/1100
	SHC6	44.00	20.20	1.75	2.00	4.00	Ø1.5	Ø2.00	32.00	25.70	28.35	40.40	0.50	10.70	330x44	160	5/800
	SHC7	44.00	20.20	1.75	2.00	4.00	Ø1.5	Ø2.00	32.00	25.30	30.70	40.40	0.50	12.86	330x44	125	5/625
SL & SLCS	S4	32.00	14.20	1.75	2.00	4.00	Ø1.5	Ø2.00	24.00	15.30	15.90	28.40	0.50	10.15	330x32	250	5/1250
	S5	32.00	14.20	1.75	2.00	4.00	Ø1.5	Ø2.00	24.00	17.30	18.10	28.40	0.50	11.50	330x32	200	5/1000
	SH3	32.00	14.20	1.75	2.00	4.00	Ø1.5	Ø2.00	24.00	14.27	16.30	28.40	0.50	9.57	330x32	250	5/1250
	SH4	32.00	14.20	1.75	2.00	4.00	Ø1.5	Ø2.00	24.00	16.81	17.57	28.40	0.50	10.48	330x32	225	5/1125
	SH5	32.00	14.20	1.75	2.00	4.00	Ø1.5	Ø2.00	24.00	19.40	16.81	19.35	0.50	10.25	330x32	200	5/1000
	SH6A	44.00	20.20	1.75	2.00	4.00	Ø1.5	Ø2.00	32.00	24.00	24.80	40.40	0.50	10.30	330x44	150	5/750
	SC3	32.00	14.20	1.75	2.00	4.00	Ø1.5	Ø2.00	24.00	14.30	16.30	28.40	0.50	9.10	330x32	300	5/1500
	SC4	32.00	14.20	1.75	2.00	4.00	Ø1.5	Ø2.00	24.00	14.90	18.10	28.40	0.50	9.40	330x32	250	5/1250
	SC5	32.00	14.20	1.75	2.00	4.00	Ø1.5	Ø2.00	24.00	17.12	19.61	28.40	0.50	10.13	330x32	220	5/1100
	SHC4	32.00	14.20	1.75	2.00	4.00	Ø1.5	Ø2.00	24.00	18.10	22.00	28.40	0.50	9.50	330x32	220	5/1100
	SHC5	44.00	20.20	1.75	2.00	4.00	Ø1.5	Ø2.00	32.00	20.10	23.00	40.40	0.50	10.82	330x44	200	5/1000
SHC6	44.00	20.20	1.75	2.00	4.00	Ø1.5	Ø2.00	32.00	25.70	28.35	40.40	0.50	10.70	330x44	160	5/800	
SH50	S5	32.00	14.20	1.75	2.00	4.00	Ø1.5	Ø2.00	24.00	17.40	18.20	28.40	0.50	11.00	330x32	200	5/1000
	SH6A	44.00	20.20	1.75	2.00	4.00	Ø1.5	Ø2.00	32.00	24.00	24.80	40.40	0.50	10.30	330x44	150	5/750
SH150	S4	32.00	14.20	1.75	2.00	4.00	Ø1.5	Ø2.00	24.00	15.30	15.90	28.40	0.50	10.15	330x32	250	5/1250
	S5	32.00	14.20	1.75	2.00	4.00	Ø1.5	Ø2.00	24.00	17.30	18.10	28.40	0.50	11.50	330x32	200	5/1000
	SH6A	44.00	20.20	1.75	2.00	4.00	Ø1.5	Ø2.00	32.00	23.80	24.60	40.40	0.50	10.30	330x44	150	5/750
	SHC7	44.00	20.20	1.75	2.00	4.00	Ø1.5	Ø2.00	32.00	25.30	30.70	40.40	0.50	12.86	330x44	125	5/625
SH260	S4	32.00	14.20	1.75	2.00	4.00	Ø1.5	Ø2.00	24.00	15.30	15.90	28.40	0.50	10.15	330x32	250	5/1250
	S5	32.00	14.20	1.75	2.00	4.00	Ø1.5	Ø2.00	24.00	17.30	18.10	28.40	0.50	11.50	330x32	200	5/1000
	SH6A	44.00	20.20	1.75	2.00	4.00	Ø1.5	Ø2.00	32.00	24.00	24.80	40.40	0.50	10.30	330x44	150	5/750
	SHC7	44.00	20.20	1.75	2.00	4.00	Ø1.5	Ø2.00	32.00	25.30	30.70	40.40	0.50	12.86	330x44	125	5/625
SCS	SC4A	32.00	14.20	1.75	2.00	4.00	Ø1.5	Ø2.00	24.00	15.10	18.10	28.40	0.50	7.00	330x32	220	5/1100



Tape & Reel Packaging and Dimensions

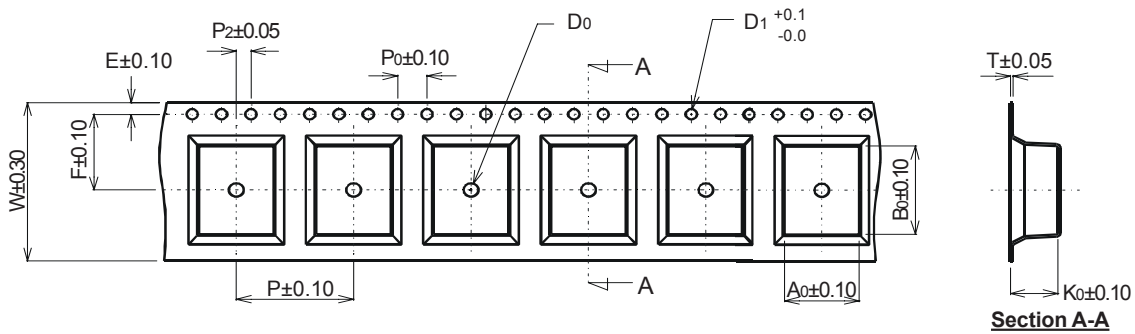

Type	Package Size	Dimensions in mm												Reel Size	Quantity (Pcs/Reel)	Quantity (Reel/Cased)
		W	F	E	P ₂	P ₀	D ₀	D ₁	P	A ₀	B ₀	T	K ₀			
SL	S3	24.00	11.50	1.75	2.00	4.00	Ø1.50	Ø1.50	20.00	14.30	14.50	0.50	8.95	330x24	300	5/1500
CMPS	SC2	24.00	11.50	1.75	2.00	4.00	Ø1.50	Ø1.50	12.00	12.30	12.30	0.40	5.60	330x24	425	5/2125
LCP	LCP1	16.00	11.75	1.75	2.00	4.00	Ø1.50	Ø1.50	12.00	7.30	7.30	0.40	5.00	330x16	600	5/3000
	LCP2	24.00	11.50	1.75	2.00	4.00	Ø1.50	Ø1.50	16.00	9.30	9.30	0.45	6.20	330x24	450	5/2250
	LCP3	24.00	11.50	1.75	2.00	4.00	Ø1.50	Ø1.50	16.00	11.30	11.30	0.45	6.60	330x24	375	5/1875
	LCP4	24.00	11.50	1.75	2.00	4.00	Ø1.50	Ø1.50	20.00	12.30	12.30	0.40	6.80	330x24	350	5/1750
	LCP5	24.00	11.50	1.75	2.00	4.00	Ø1.50	Ø1.50	20.00	12.30	12.30	0.40	8.80	330x24	250	5/1250
SLS	S1	24.00	11.50	1.75	2.00	4.00	Ø1.50	Ø1.50	16.00	8.90	9.30	0.35	5.90	330x24	600	5/3000
	S2	24.00	11.50	1.75	2.00	4.00	Ø1.50	Ø1.50	16.00	11.30	11.50	0.50	7.93	330x24	375	5/1875
SH150S	S1	24.00	11.50	1.75	2.00	4.00	Ø1.50	Ø1.50	16.00	8.90	9.30	0.35	5.90	330x24	600	5/3000
	S2	24.00	11.50	1.75	2.00	4.00	Ø1.50	Ø1.50	16.00	11.30	11.50	0.50	7.93	330x24	375	5/1875

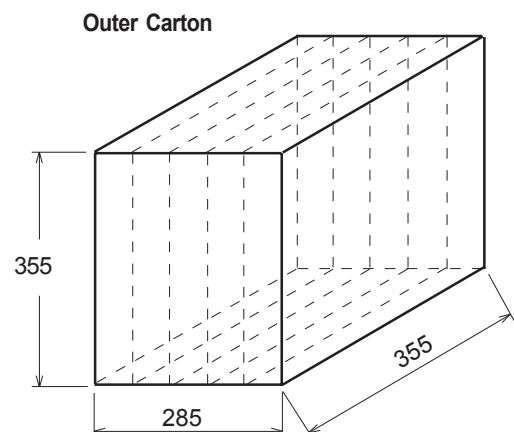
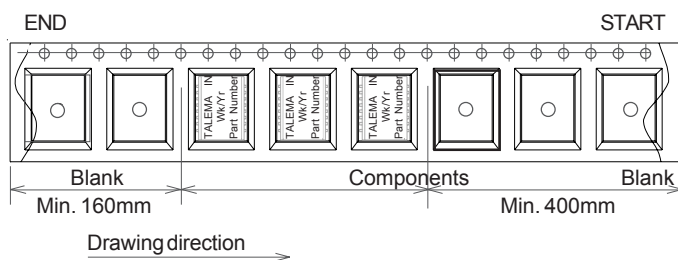

Transformers and Inductors for SMPS Applications

A complete range of transformers and Inductors for SMPS applications is available from Talema, produced to your specifications:

- Drive Transformers
- Control Transformers
- Flyback Transformers
- High Current Inductors
- Current Transformers
- Common Mode Chokes
- Output Transformers
- Custom Assemblies

A wide variation of high frequency winding techniques and construction are employed:

- Multi-strand copper
- Foil
- Litz
- Heavy Duty Copper
- Triple Insulated Wire
- Margin Tapes

The Talema design team, consisting of engineering and procurement specialists, can help with:

- Sourcing cost-effective alternative materials
- Requirements for safety standards (e.g., EN60065, EN60950)
- Design Assistance



High capacity in-house production capabilities permit Talema to meet volume requirements for highly competitive ferrite transformers. Based on the most popular ferrite product types and footprints used by equipment manufacturers (RM, EE/EF, EFD/EVD, EI, EP, ER and ETD, P, PT, PTS, PQ and U cores) Talema offers quick turn around on quotation and sample requests, saving time and expense.

TALEMA manufacturing facilities are certified to ISO-9001:2000, TS-16949:2002 and ISO-14001:2004 ensuring the highest quality and full environmental compliance.



Note: The transformers shown on these pages are fully RoHS compliant and meet lead free reflow level J-STD-020C.

RM Magnetics

Type: Vertical
Mounting: THT and SMD
Range: RM4 - RM14



EE/EF Magnetics

Type: Vertical & Horizontal
Mounting: THT and SMD
Range: EE5 - EE80
Sections: Single, Double and Multi-chamber

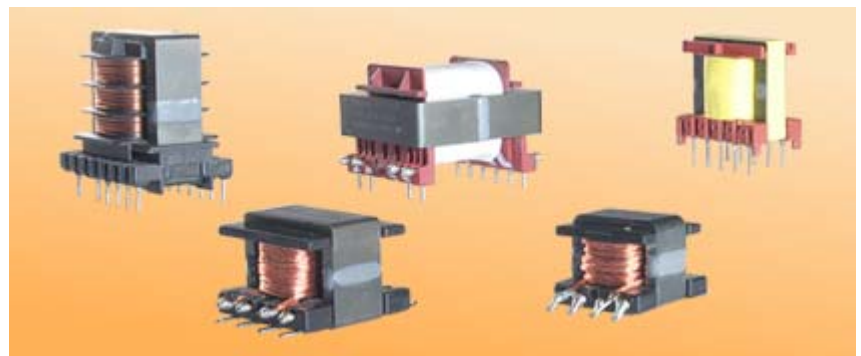

Terminals:

THT - Available in "L" or Straight Pin versions.

SMD - Available in "L", "J", "U/C" or GW versions.



Transformers and Inductors for SMPS Applications

EFD/EVD Magnetics

Type: Horizontal
Mounting: THT and SMD
Range: EFD10 - EFD30
Range: EVD15 - EVD30
Sections: Single. Double and Multi-chamber



EI Magnetics

Type: Vertical & Horizontal
Mounting: THT
Range: EI16 - EI40



EP Magnetics

Type: Horizontal
Mounting: THT and SMD
Range: EP5 - EP20
Sections: Single and Double

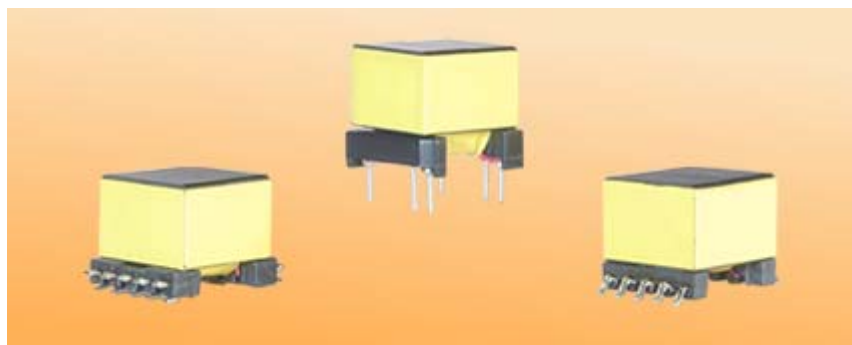

ER Magnetics

Type: Vertical & Horizontal
Mounting: THT and SMD (ER9.5 & ER11)
Range: ER9.5 - ER54



ETD Magnetics

Type: Vertical & Horizontal
Mounting: THT
Range: ETD29 - ETD59



Terminals:

THT - Available in "L" or Straight Pin versions.

SMD - Available in "L", "J", "U/C" or GW versions.

Transformers and Inductors for SMPS Applications

P Magnetics

Type: Vertical
Mounting: THT
Range: P9 - P66



PT Magnetics

Type: Vertical
Mounting: THT
Range: PT14 - PT23



PTS Magnetics

Type: Vertical
Mounting: THT
Range: PTS14 - PTS40



PQ Magnetics

Type: Vertical
Mounting: THT
Range: PQ20 - PQ50



U Magnetics

Type: Horizontal
Mounting: THT
Range: U10 - U30



Terminals:

THT - Available in "L" or Straight Pin versions.

SMD - Available in "L", "J", "U/C" or GW versions.

Sales & Marketing, Design and Manufacturing Facilities

<http://www.talema-nuvotem.com>

Eastern Europe & Czech Republic

NT MAGNETICS s.r.o.
Chebská 27
322 00 Plzeň
Tel: Int. + 420 377 - 338 351
Fax: Int. + 420 377 - 338 350
Email: talema@talema.cz
Web Site:
www.ntmagnetics.cz

Germany

TALEMA ELEKTRONIK GMBH
Sembdnerstr. 5, Postfach 2523
82110 Germering
Tel: Int. + 49 89 - 841 00 - 0
Fax: Int. + 49 89 - 841 00 25
Email: info@talema.de

Ireland

NUVOTEM TEO.
Crolly
Co. Donegal
Tel: Int. + 353 74 - 954 8666
Fax: Int. + 353 74 - 954 8139
Email: info@nuvotem.com

India

TALEMA ELECTRONIC PVT. LTD.
Opposite the SIDCO Industrial Estate
Gins Towers
4/5S.H/1, Omalur Main Road
Salem - 636 004, Tamil Nadu
Tel: Int. + 91 427 - 244 1325
Fax: Int. + 91 427 - 243 0034
E-mail: talema@talemaindia.com
Web Site: www.talemaindia.com



Authorised Talema Sales Representatives and Distributors

Sales Representatives

Germany

PLZ 1, 4, 5, 6, 8 & 9

TALEMA ELEKTRONIK GMBH
Sembdnerstr. 5, Postfach 2523
82110 Germering
Tel: Int. + 49 89 841 00 - 0
Fax: Int. + 49 89 841 00 25
Email: info@talema.de

PLZ 2 & 3 (less 35 & 36)

H. J. MERCK & Co. GmbH
Hasenhöhe 128
22587 Hamburg
Tel: Int. + 49 40 87 08 63-0
Fax: Int. + 49 40 87 08 63-33
E-mail: info@hj-merck.de

PLZ 7

BERNDBIELER
Industrievertretung
Max-Eyth-Straße 1
72379 Hechingen
Tel: Int. + 49 7471 1804-0
Fax: Int. + 49 7471 1804-10
E-mail: bieler@bernd-bieler.de

Austria

TALEMA ELEKTRONIK GMBH
Sembdnerstr. 5, Postfach 2523
82110 Germering
Tel: Int. + 49 89 841 00 - 0
Fax: Int. + 49 89 841 00 25
Email: info@talema.de

Australia

TORTECHPTY. LTD.
POB 194
North Strathfield,
Sydney, N.S.W. 2137
Tel: Int. + 61 2 9642 6003
Fax: Int. + 61 2 9642 6127
E-Mail: tortech@ozemail.com.au
Web Site: www.tortech.com.au

Benelux

ISATRONICK B.V.B.A.
Doolhoflaan 17
B-2640 Mortsel
Tel: Int. + 32 3 448 1976
Fax: Int. + 32 3 448 1195
E-Mail: info@isatronick.be
Web Site: www.isatronick.be

Denmark & Sweden

NORDTEK DANMARK
Horsensvej 134
DK-8300 Odder
Tel: Int. + 45 86 554 344
Fax: Int. + 45 86 554 644
E-Mail: post@nordtek.dk
Web Site: www.nordtek.dk

Italy

TECHNOLASAELETRONICA
Via Macello, 65/B
I-39100 Bolzano
Tel: Int. + 39 0471 305 400
Fax: Int. + 39 0471 305 444
E-Mail: sales@technolasa.com

France

E.S.I.A
5-7 Place Marcel Rebuffat
Courtaboeuf 7 Villejust
91971 Courtaboeuf Cedex
Tel: Int. + 33 1 6931 4410
Fax: Int. + 33 1 6931 4425
E-Mail: esia@wanadoo.fr
Web Site: www.esia.fr

Spain

OTTORATING S.A.
Castellnou, 31-33
08017 Barcelona
Tel: Int.+34 93 252 2708
Fax: Int.+34 93 205 6264
E-mail: Info@rating.es
Web Site: www.rating.es

Switzerland

BTB COMPONENTS AG
Im Chlösterli 4
CH-8902 Urdorf
Tel: Int. + 41 44 734 4888
Fax: Int. + 41 44 734 4892
E-mail: info@btbcomponents.ch

UK

DELTA COMPONENTS LTD.
The Courtyard
Seven Acres, Smallfield Road
Horne, Surrey RH6 9JP
Tel: Int. + 44 1342 844 555
Fax: Int. + 44 1342 844 552
sales@deltacomponents.com
www.deltacomponents.com

USA

H. F. Transformers, Chokes & Inductors
ALFAMAG ELECTRONICS LLC
945 Parkwood
PO Box 668
Rolla, Missouri 65402
Tel: Int.+573 364 2422
Fax: Int.+573 364 5390
E-Mail: sales@alfamag.com
Web Site: www.alfamag.com

50/60 Hz Toroidal Transformers
AMVECO MAGNETICS, INC.
11222 Richmond Ave., Suite 120
Houston, TX 77042
E-Mail: sales@amveco.com
Web Site: www.amveco.com

Distributors

Germany

BÜRKLIN OHG MÜNCHEN
Schillerstr. 41
80336 München
Tel: Int.+49 89 558 75-0
Fax: Int.+49 89 558 75-421
E-Mail: info@buerklin.de
Web: www.buerklin.com

BÜRKLIN OHG DÜSSELDORF

Hoherweg 245
40231 Düsseldorf
Tel: Int.+49 211 9067-0
Fax: Int.+49 211 9067-125
E-Mail: info@buerklin.de
Web: www.buerklin.com

SCHUKATELECTRONIC VERTRIEBS GMBH

Daimlerstraße 26
40789 Monheim
Tel: Int.+49 2173 9505
Fax: Int.+49 2173 950999
Web: www.schukat.com

RUTRONIK ELEKTRONISCHE BAULEMENTE GMBH

Industriestraße 2
75228 Ispringen/Pforzheim
Tel: Int.+49 7231 801-0
Fax: Int.+49 7231 82282
E-Mail: rutronik@rutronik.com
Web: www.rutronik.com

Italy

RUTRONIK ITALIA S.r.l
21, Via Caldera
Centro Direzionale S.Siro
20153 Milano
Tel: Int.+39 02 40951 1
Fax: Int.+39 02 40951 224
E-Mail: MI@rutronik.com
Web: www.rutronik.com

Switzerland

**RUTRONIK ELEKTRONISCHE
BAUELEMENTE AG**
Hölzliwisenstraße 5
CH-8604 Volketswil
Tel: Int.+41 44 947 3737
Fax: Int.+41 44 947 3747
E-Mail: rutronik_ch@rutronik.com

UK

RS COMPONENTS LTD.
Birchington Road
Corby
Northants, NN17 9RS
Tel: Int.+44 8457 201201
Fax: Int.+44 845 850 9911
www.rs-components.com

Sales & Marketing, Design and Manufacturing Facilities

<http://www.talema-nuvotem.com>

Eastern Europe & Czech Republic

NT MAGNETICS s.r.o.
Chebská 27
322 00 Plzeň
Tel: Int. + 420 377 - 338 351
Fax: Int. + 420 377 - 338 350
Email: talema@talema.cz
Web Site: www.ntmagnetics.cz

Germany

TALEMA ELEKTRONIK GMBH
Sembdnerstr. 5, Postfach 2523
82110 Germering
Tel: Int. + 49 89 - 841 00 - 0
Fax: Int. + 49 89 - 841 00 25
Email: info@talema.de

Ireland

NUVOTEM TEO.
Crolly
Co. Donegal
Tel: Int. + 353 74 - 954 8666
Fax: Int. + 353 74 - 954 8139
Email: info@nuvotem.com

India

TALEMA ELECTRONIC PVT. LTD.
Opposite the SIDCO Industrial Estate
Gins Towers
4/5S.H/1, Omalur Main Road
Salem - 636 004, Tamil Nadu
Tel: Int. + 91 427 - 244 1325
Fax: Int. + 91 427 - 243 0034
E-mail: talema@talemaindia.com
Web Site: www.talemaindia.com



nt
magnetics

nuvotem

Summary TOTAL PROGRAM

SECTION 1

- TOROIDAL 50/60Hz TRANSFORMERS



SECTION 2

- TOROIDAL PCB TRANSFORMERS



SECTION 3

- ELEVEN GOOD REASONS TO SELECT TALEMA TOROIDAL TRANSFORMERS

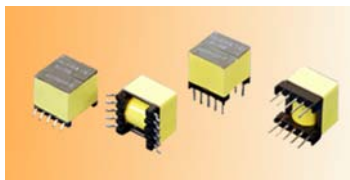

SECTION 4

- CHOKES, INDUCTORS AND TRANSFORMERS FOR POWER APPLICATIONS

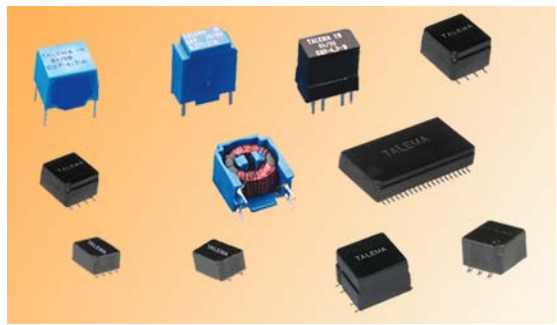

SECTION 5

- COMPONENTS FOR TELECOMMUNICATIONS AND DATA LINE TECHNOLOGY



SECTION 6

- CURRENT COMPENSATED EMI NOISE SUPPRESSION CHOKES



SECTION 7

- CURRENT SENSE TRANSFORMERS AND INDUCTORS



SECTION 8

- LAN MAGNETIC COMPONENTS FOR ETHERNET APPLICATIONS

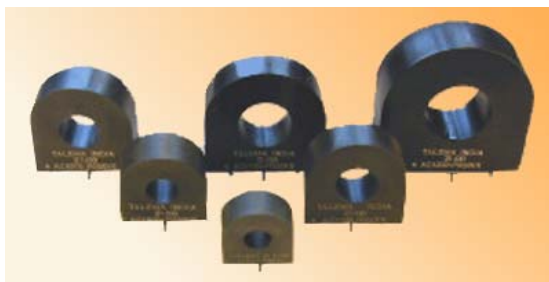

SECTION 9

- T1/E1/CEPT-PRI - T3/DS3/E3/STS-1 FOR TELECOMMUNICATION PRODUCTS

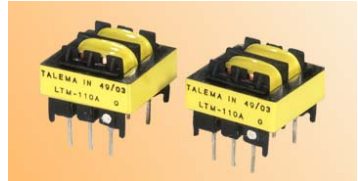

SECTION 10

- U INTERFACE TRANSFORMERS FOR COMMUNICATIONS AND DATA LINE TECHNOLOGY



SECTION 11

- TRANSFORMERS FOR BROADBAND ACCESS AND FIBRE CHANNEL INTERFACE

